



Cast Iron-, All-Steel- and Aluminium Die Sets



Cast Iron-, All-Steel- and Aluminium Die Sets and Plates Remarks and Guide Lines

Execution

Contour faces of FIBRO Steel Die Sets are fully machined. Contour faces of Aluminium Die Sets are sawn, as are those of Aluminium Plates. However, these contour faces can also be machined on request. To all die set plates, a general thickness tolerance of ± 2 mm applies.

Guide Elements

Guide pillars DIN 9825/ISO 9182 (209.19.) and headed guide bushes DIN 9831/ISO 9448 (2081.) are normal equipment on all-steel die sets.

Detailed information under Guide Elements.

Lifting Aids on Die Sets

Plate sizes with edges $a_1+b_1 \leq 1000$ mm, and die sets weighting more than 100 kg, are fitted with threaded holes for two lifter eyebolts per plate. Eyebolts etc. are supplied against special order.

Special Die Sets and Plates to Customers' Drawings

Die sets and plates up to size 2200x1100 mm (external dims.) will be made to customer's drawings, with any special features and highest precision.

Special Machining Features

Wherever possible, all larger apertures or holes should be done by FIBRO before final machining of die sets, for their application at the customer's works must result in die set distortion and impairment of accuracy.

Enquiry Forms for Special Die Sets

Special pre-printed forms for enquiries and ordering are available on request. All the customer has to do is the filling-in of dimensions and the specifying of guide elements or special machining features where applicable.

Contents

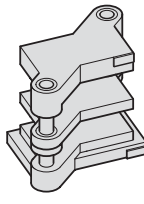
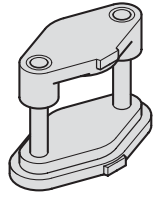
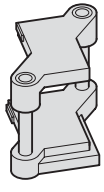
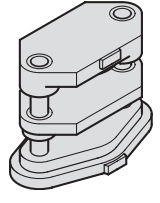
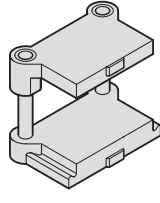
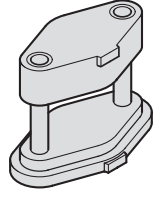
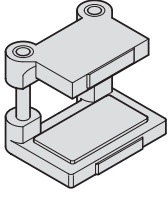
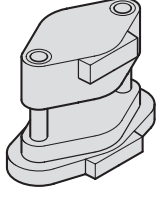
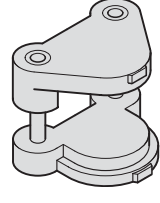
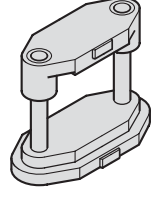
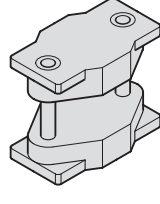
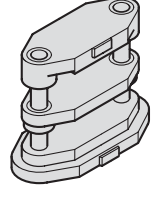
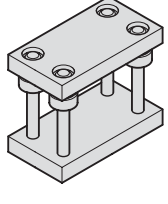
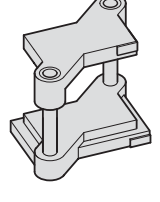
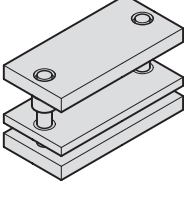
| | | | | | |
|---|--|-----|--|---|--------|
| | Notes on guide elements | A7 |  | 201.23. Die set | A17 |
|  | 201.01. Die set DIN 9812 Type D/DG | A10 |  | 201.26. Die set | A18 |
|  | 201.03. Die set DIN 9814 Type D/DG | A11 |  | 201.31. Die set DIN 9822 Shape C | A19 |
|  | 201.05. Die set DIN 9816 Shape D | A12 |  | 201.33. Die set | A20 |
|  | 201.07. Die set ~DIN 9816 Shape D | A13 |  | 201.36. Die set | A21 |
|  | 201.11. Die set DIN 9812 Shape C/CG | A14 |  | 201.39. Fine blanking die set | A22 |
|  | 201.13. Die set DIN 9814 Shape C/CG | A15 |  | 2010. Die set ~DIN 9868/ISO 11415 | A24-31 |
|  | 201.21. Die set DIN 9819 Shape C/CG | A16 |  | 201.45. Die set to customers' specifications, Steel | A32 |

Contents

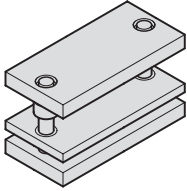
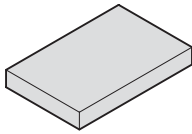
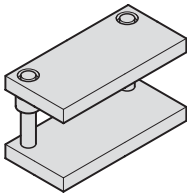
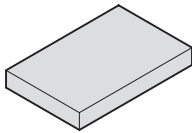
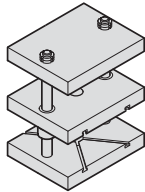
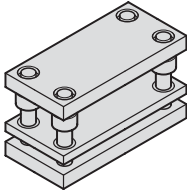
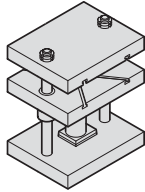
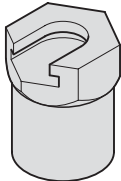
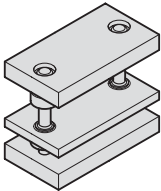
| | | | | | |
|--|--|--------|---|-----------------------------------|--------|
| | 201.65. | A32 | | 2010.57. | A36-37 |
| | Die set to customers' specifications, Aluminium | | | Die set ECO-LINE | |
|  | 201.46. | A33 | | 2010.59. | A36-37 |
| | Die set to customers' specifications, Steel | | | Die set ECO-LINE | |
| | 201.66. | A33 |  | 2900. | A38 |
| | Die set to customers' specifications, Aluminium | | | Steel plate ISO 6753-1 | |
|  | 201.47. | A34 |  | 2910. | A39 |
| | Die set to customers' specifications, Steel | | | Aluminium plate ~ISO 6753-1 | |
| | 201.67. | A34 |  | 2011.45. | A40 |
| | Die set to customers' specifications, Aluminium | | | Die set press unit | |
|  | 201.49. | A35 |  | 201.145. | A41 |
| | Die set to customers' specifications, Steel | | | Die set press unit | |
| | 201.69. | A35 |  | | A42 |
| | Die set to customers' specifications, Aluminium | | | Die set press units - Accessories | |
|  | 2010.55. | A36-37 | | 212.16.1. | A42 |
| | Die set ECO-LINE | | | Spigot holder | |

Contents

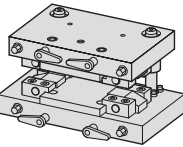
| | | | | |
|---|---|--|---|-------------------|
| <p>212.11. Coupling spigot</p> | <p>A42</p> |  | <p>201.98. Aligning- and tryout press unit</p> | <p>A59</p> |
| <p>212.15. Coupling spigot</p> | <p>A42</p> | | | |
| <p>A43-46 Special die set to customer's specifications</p> | | | | |
|  | <p>201.50. Progression lamination die set unit</p> | <p>A47-52</p> | | |
|  | <p>201.95. Tooling pallet die set</p> | <p>A53-57</p> | | |
| <p>A58 Tooling pallet die set - Accessories</p> | | | | |
| <p>201.96. Pallet carrier plate</p> | <p>A58</p> | | | |
| <p>201.97. Bolster insert plate</p> | <p>A58</p> | | | |

Notes on Guide Elements

FIBRO Precision Sliding Guides – Carbonitrided Sintered Ferrite Bushes

These guides employ bushes made from sintered ferrite of high purity with carbonitrided surface. Bearing surfaces are fine-ground.

The sintered ferrite has a porosity content of 18-20 % by volume, vacuum filled with special lubricant FIBROLIT LD. As additional long term lubrication it is recommended to fill up the groove in the bushing with FIBROLIT LD 280.34, see chapter H. Even under arduous running conditions, this material can be relied upon for good protection against oil film rupture.

Under no circumstances must molybdenum disulfite be added to the lubricant.

For bearing clearance ranges, see chapter D.

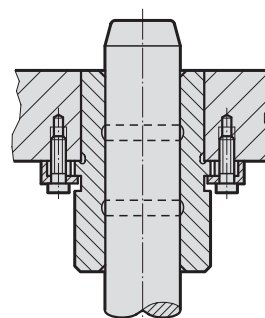

FIBRO Precision Sliding Guides, bronze-coated

consists of a steel body with bronze-coated running surface with helical oil groove and a grease nipple for lubrication.

The steel body guarantees excellent resistance to breaking, even when subject to high loading at the edges.

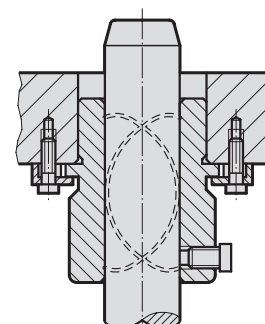

FIBRO High Precision Ball Bearing Guides

Careful manufacture at narrowest tolerances, and exactly the right amount of preloading* result in a play-free guide element of exceptional performance potential.

Our superfinished running surfaces further enhance the advantages of ball bearing guides.

Toolmakers favour ball bearing guides because of their free movement on the bench.

FIBRO ball bearing guides can be equipped with a choice of brass or aluminium ball cages, which have proved to be very successful in practice due to their ball density and stability

Ball bearing guides with their point contact of the balls remain somewhat sensitive to shock and sustained radial loads. To some extent, generous dimensioning of pillar diameters helps to compensate for this inherent disadvantage.

* Average preloading:

4 µm on pillars from 8 to 12 mm diameter

7– 9 µm on pillars from 15 to 16 mm diameter

9–11 µm on pillars from 18 to 42 mm diameter

11–13 µm on pillars from 50 to 80 mm diameter

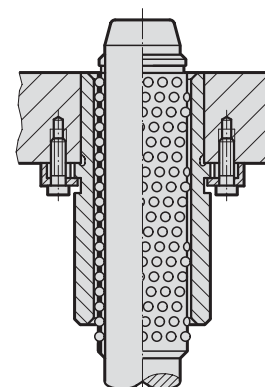

FIBRO Precision Roller Guides

The profile roller cages are in linear contact with the guide bushing and guide pillar. This feature offers much greater capacity for radial loads in the individual roller than an identical size of ball bearing.

The caulking of the roller bearing arrangement is implemented with the same FIBRO-specific solution as that used in ball cages.

The profile rollers are arranged in a spiral formation in an axial direction. This gives each profile roller its own path. The roller cages are designed with a recess for a circlip conforming to DIN 471.

The much larger contact area with the ball bearing guide permits a significant reduction in preload values.

The following preload values apply to FIBRO Roller Guides:

| For static loads/low velocities, pillar diameters | For Dynamic Loads/High Velocities, pillar diameters |
|--|--|
| up to Ø 25 = 2,5 µm | up to Ø 25 = 1,5 µm |
| Ø 30/32 = 3 µm | Ø 30/32 = 2 µm |
| Ø 40-50 = 3,5 µm | Ø 40-50 = 2,5 µm |
| Ø 63 = 4 µm | Ø 63 = 3 µm |

Use only pairing class
guide pillar red = .30
guide bush yellow = .10

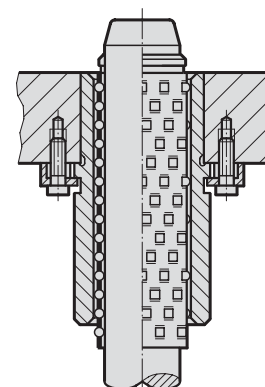



Cast Iron Die Sets



Die set DIN 9812 Type D/DG



201.01.

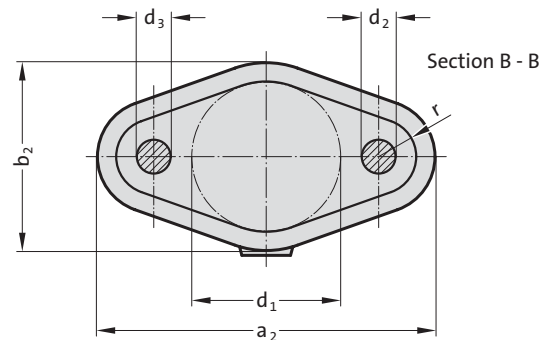
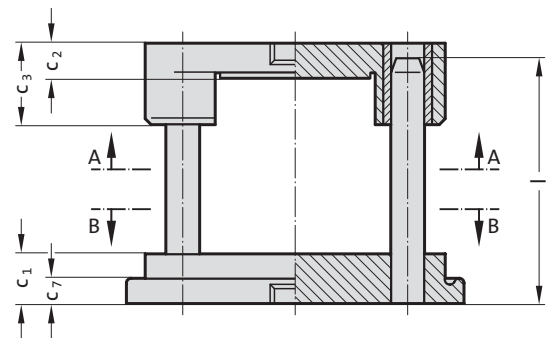
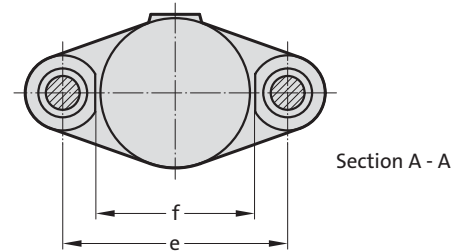

Guide Elements

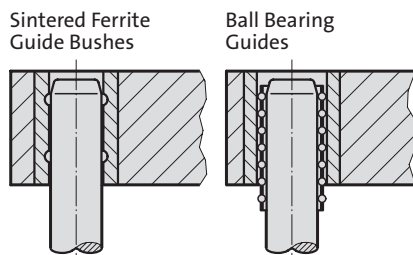

Order No (part II)
Available without or
with shank thread
in top bolster

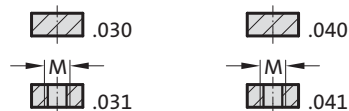

201.01. Die set DIN 9812 Type D/DG

| Order No part 1* | Work area | | | | | | | | | | | | | |
|------------------|----------------|----------------|----------------|----------------|----------------|----------------|----------------|----------------|----------------|-----|-----|-----|----|--------|
| | d ₁ | a ₂ | b ₂ | c ₁ | c ₂ | c ₃ | c ₇ | d ₂ | d ₃ | e | f | l | r | M |
| 201.01.063. | 63 | 182 | 100 | 40 | 25 | 60 | 20 | 16 | 15 | 106 | 73 | 140 | 20 | 16x1,5 |
| 201.01.080. | 80 | 236 | 120 | 50 | 30 | 80 | 30 | 20 | 19 | 140 | 90 | 160 | 28 | 20x1,5 |
| 201.01.100. | 100 | 275 | 140 | 50 | 30 | 80 | 30 | 25 | 24 | 165 | 110 | 160 | 35 | 20x1,5 |
| 201.01.125. | 125 | 300 | 165 | 50 | 30 | 80 | 30 | 25 | 24 | 190 | 139 | 160 | 35 | 20x1,5 |
| 201.01.160. | 160 | 360 | 200 | 56 | 40 | 90 | 30 | 32 | 30 | 240 | 174 | 180 | 40 | 24x1,5 |
| 201.01.180. | 180 | 380 | 220 | 56 | 40 | 90 | 30 | 32 | 30 | 260 | 194 | 180 | 40 | 24x1,5 |
| 201.01.200. | 200 | 400 | 240 | 56 | 40 | 90 | 30 | 32 | 30 | 280 | 218 | 180 | 40 | 24x1,5 |
| 201.01.250. | 250 | 496 | 300 | 56 | 50 | 100 | 30 | 40 | 38 | 350 | 268 | 200 | 48 | 30x2 |
| 201.01.315. | 315 | 563 | 365 | 63 | 50 | 100 | 30 | 40 | 38 | 417 | 333 | 224 | 48 | 30x2 |

*Order No Part 2 = complete guide type

Ordering Code (example):

| | |
|---|------------------|
| Die set DIN 9812 Type D/DG | = 201.01. |
| Work area D1 63 mm | = 63. |
| Type of guides FA Sintered ferrite | = 3 |
| Shank thread ZG without | = 0 |
| Order No | = 201.01. 63. 30 |

Die set DIN 9814 Type D/DG



201.03.

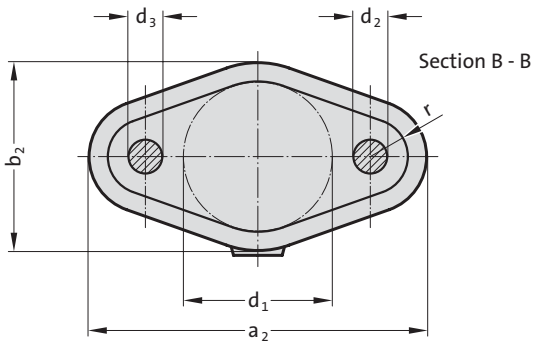
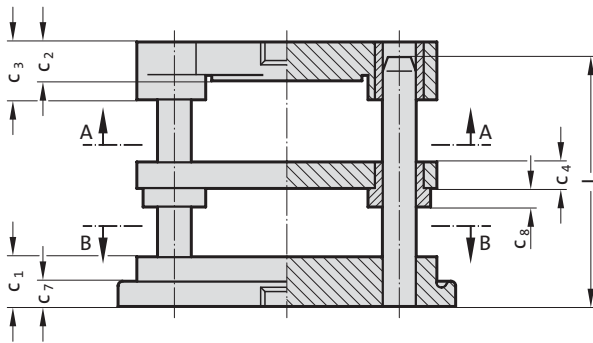
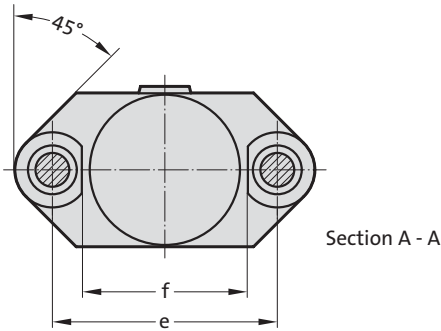

Guide Elements

Sintered Ferrite Guide Bushes

Ball Bearing Guides

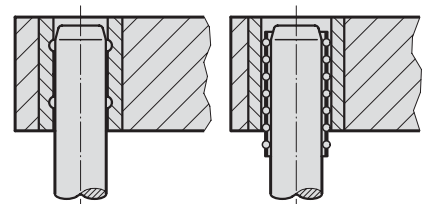

Stripper

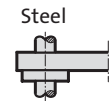
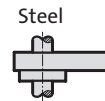

Order No (part II)
Available without or
with shank thread
in top bolster

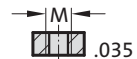

201.03. Die set DIN 9814 Type D/DG

| Order No part 1* | Work area | | | | | | | | | | | | | | | |
|------------------|----------------|----------------|----------------|----------------|----------------|----------------|----------------|----------------|----------------|----------------|----------------|-----|-----|-----|----|--------|
| | d ₁ | a ₂ | b ₂ | c ₁ | c ₂ | c ₃ | c ₄ | c ₇ | c ₈ | d ₂ | d ₃ | e | f | l | r | M |
| 201.03.100. | 100 | 275 | 140 | 50 | 30 | 50 | 22 | 30 | 18 | 25 | 24 | 165 | 119 | 160 | 35 | 20x1.5 |
| 201.03.125. | 125 | 300 | 165 | 50 | 30 | 50 | 22 | 30 | 18 | 25 | 24 | 190 | 144 | 160 | 35 | 20x1.5 |
| 201.03.160. | 160 | 360 | 200 | 56 | 40 | 60 | 27 | 30 | 18 | 32 | 30 | 240 | 184 | 180 | 40 | 24x1.5 |

*Order No Part 2 = complete guide type

Ordering Code (example):

| | |
|------------------------------------|--------------------|
| Die set DIN 9814 Type D/DG | = 201.03. |
| Work area D1 100 mm | = 100. |
| Type of guides FA Sintered ferrite | = 03 |
| Shank thread ZG without | = 4 |
| Order No | = 201.03. 100.03 4 |

Die set DIN 9816 Shape D



201.05.

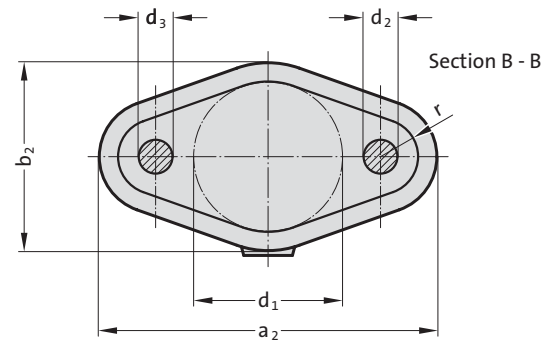
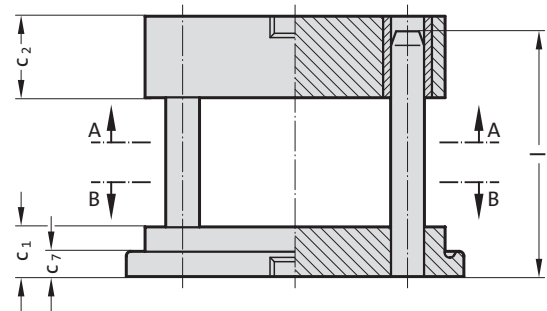
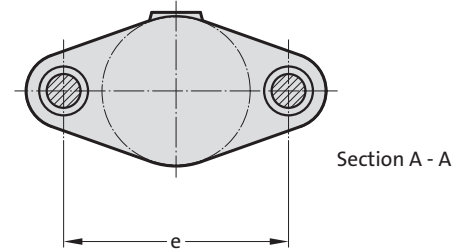

Guide Elements

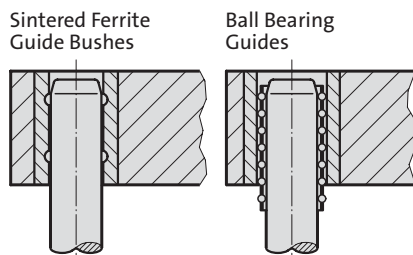

Order No (part II)
Without shank thread
in top bolster



201.05. Die set DIN 9816 Shape D

| Order No part 1* | Work area | | | | | | | | | | |
|------------------|----------------|----------------|----------------|----------------|----------------|----------------|----------------|----------------|-----|-----|----|
| | d ₁ | a ₂ | b ₂ | c ₁ | c ₂ | c ₇ | d ₂ | d ₃ | e | l | r |
| 201.05.063. | 63 | 182 | 100 | 40 | 65 | 20 | 16 | 15 | 106 | 140 | 20 |
| 201.05.080. | 80 | 236 | 120 | 50 | 70 | 30 | 20 | 19 | 140 | 160 | 28 |
| 201.05.100. | 100 | 275 | 140 | 50 | 75 | 30 | 25 | 24 | 165 | 180 | 35 |
| 201.05.125. | 125 | 300 | 165 | 50 | 80 | 30 | 25 | 24 | 190 | 180 | 35 |
| 201.05.160. | 160 | 360 | 200 | 56 | 90 | 30 | 32 | 30 | 240 | 224 | 40 |
| 201.05.200. | 200 | 400 | 240 | 56 | 100 | 30 | 32 | 30 | 280 | 224 | 40 |

*Order No Part 2 = complete guide type

Ordering Code (example):

| | | |
|--------------------------|------------------|-------------------|
| Die set DIN 9816 Shape D | | =201.05. |
| Work area D1 | 63 mm | = 063. |
| Type of guides FA | Sintered ferrite | = 030 |
| Order No | | =201.05. 063. 030 |

Die set ~DIN 9816 Shape D



201.07.

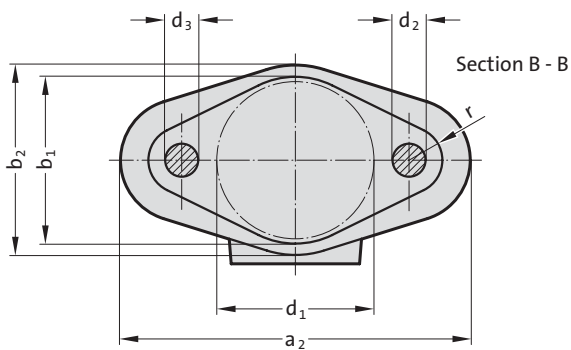
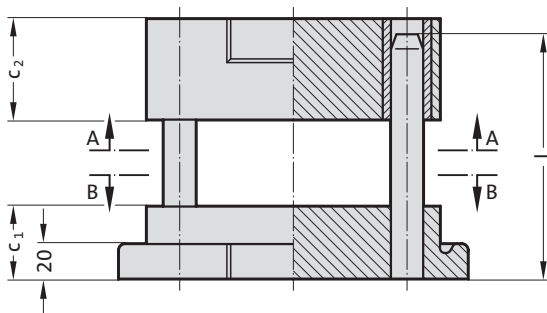
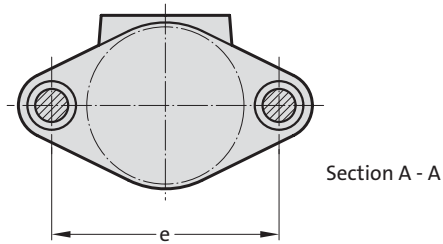
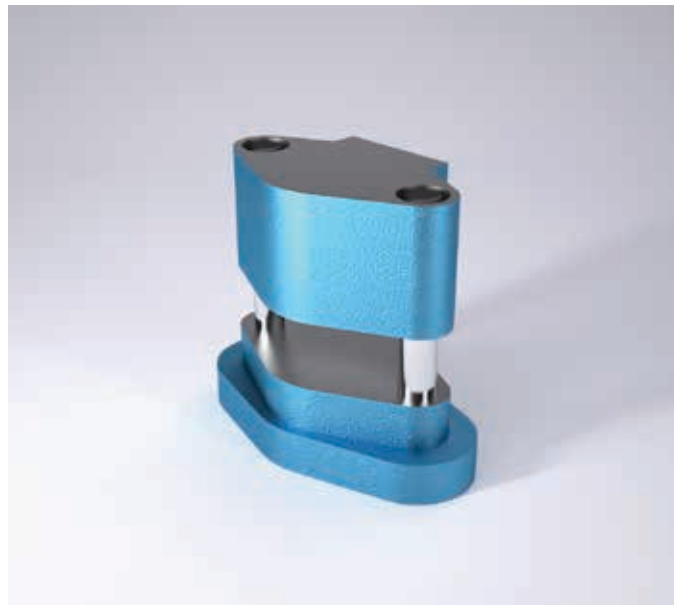

Guide Elements

Sintered Ferrite
Guide Bushes

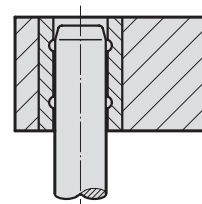

201.07. Die set ~DIN 9816 Shape D

| Order No | Work area | | | | | | | | | | |
|----------------|----------------|----------------|----------------|----------------|----------------|----------------|----------------|----------------|----|-----|----|
| | d ₁ | a ₂ | b ₁ | b ₂ | c ₁ | c ₂ | d ₂ | d ₃ | e | l | r |
| 201.07.040.030 | 40 | 112 | 45 | 55 | 36 | 40 | 16 | 15 | 66 | 100 | 13 |
| 201.07.063.030 | 63 | 142 | 68 | 78 | 40 | 55 | 16 | 15 | 90 | 125 | 14 |



201.11.

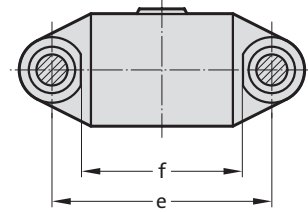

Section A - A

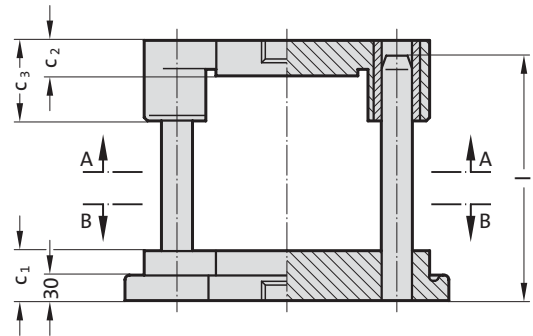

Section B - B

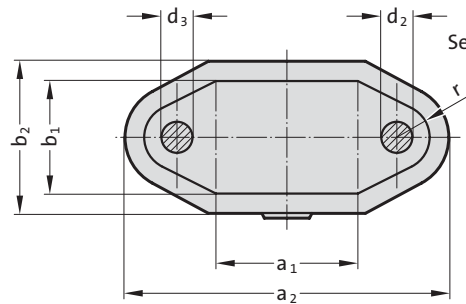

Guide Elements

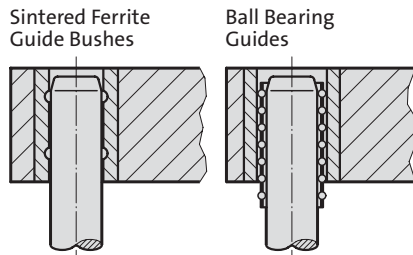

Order No (part II)
Available without or
with shank thread
in top bolster

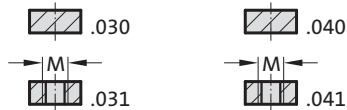

201.11. Die set DIN 9812 Shape C/CG

| Order No part 1* | Work area | | | | | | | | | | | | |
|------------------|------------------|-------|-------|-------|-------|-------|-------|-------|-----|-----|-----|-----|--------|
| | $a_1 \times b_1$ | a_2 | b_2 | c_1 | c_2 | c_3 | d_2 | d_3 | e | f | l | r | M |
| 201.11.070.050. | 70 x 50 | 170 | 70 | 40 | 22 | 50 | 20 | 19 | 110 | 73 | 140 | 20 | 20x1.5 |
| 201.11.080.063. | 80 x 63 | 235 | 103 | 50 | 30 | 80 | 20 | 19 | 140 | 90 | 160 | 27 | 20x1.5 |
| 201.11.100.063. | 100 x 63 | 253 | 103 | 50 | 30 | 80 | 20 | 19 | 158 | 110 | 160 | 27 | 20x1.5 |
| 201.11.100.080. | 100 x 80 | 265 | 120 | 50 | 30 | 80 | 25 | 24 | 165 | 110 | 160 | 30 | 20x1.5 |
| 201.11.125.080. | 125 x 80 | 290 | 120 | 50 | 30 | 80 | 25 | 24 | 190 | 139 | 160 | 30 | 20x1.5 |
| 201.11.160.080. | 160 x 80 | 325 | 120 | 50 | 30 | 80 | 25 | 24 | 225 | 174 | 160 | 30 | 20x1.5 |
| 201.11.200.080. | 200 x 80 | 365 | 120 | 50 | 30 | 80 | 25 | 24 | 265 | 218 | 160 | 30 | 20x1.5 |
| 201.11.125.100. | 125 x 100 | 290 | 140 | 50 | 40 | 90 | 25 | 24 | 190 | 139 | 160 | 30 | 24x1.5 |
| 201.11.160.100. | 160 x 100 | 325 | 140 | 50 | 40 | 90 | 25 | 24 | 225 | 174 | 160 | 30 | 24x1.5 |
| 201.11.200.100. | 200 x 100 | 395 | 140 | 56 | 40 | 90 | 32 | 30 | 280 | 218 | 180 | 37 | 24x1.5 |
| 201.11.160.125. | 160 x 125 | 355 | 165 | 56 | 40 | 90 | 32 | 30 | 240 | 174 | 180 | 37 | 24x1.5 |
| 201.11.200.125. | 200 x 125 | 395 | 165 | 56 | 40 | 90 | 32 | 30 | 280 | 218 | 180 | 37 | 24x1.5 |
| 201.11.250.125. | 250 x 125 | 445 | 165 | 56 | 40 | 90 | 32 | 30 | 330 | 268 | 180 | 37 | 24x1.5 |
| 201.11.315.125. | 315 x 125 | 510 | 165 | 56 | 40 | 90 | 32 | 30 | 395 | 333 | 180 | 37 | 24x1.5 |
| 201.11.200.160. | 200 x 160 | 395 | 200 | 56 | 50 | 100 | 32 | 30 | 280 | 218 | 200 | 37 | 30x2 |
| 201.11.250.160. | 250 x 160 | 445 | 200 | 56 | 50 | 100 | 32 | 30 | 330 | 268 | 200 | 37 | 30x2 |
| 201.11.250.200. | 250 x 200 | 496 | 250 | 63 | 50 | 100 | 40 | 38 | 350 | 268 | 224 | 48 | 30x2 |
| 201.11.315.200. | 315 x 200 | 563 | 250 | 63 | 50 | 100 | 40 | 38 | 417 | 333 | 224 | 48 | 30x2 |
| 201.11.315.250. | 315 x 250 | 563 | 300 | 63 | 50 | 100 | 40 | 38 | 417 | 333 | 224 | 48 | 30x2 |

*Order No Part 2 = complete guide type

Die set DIN 9814 Shape C/CG



201.13.

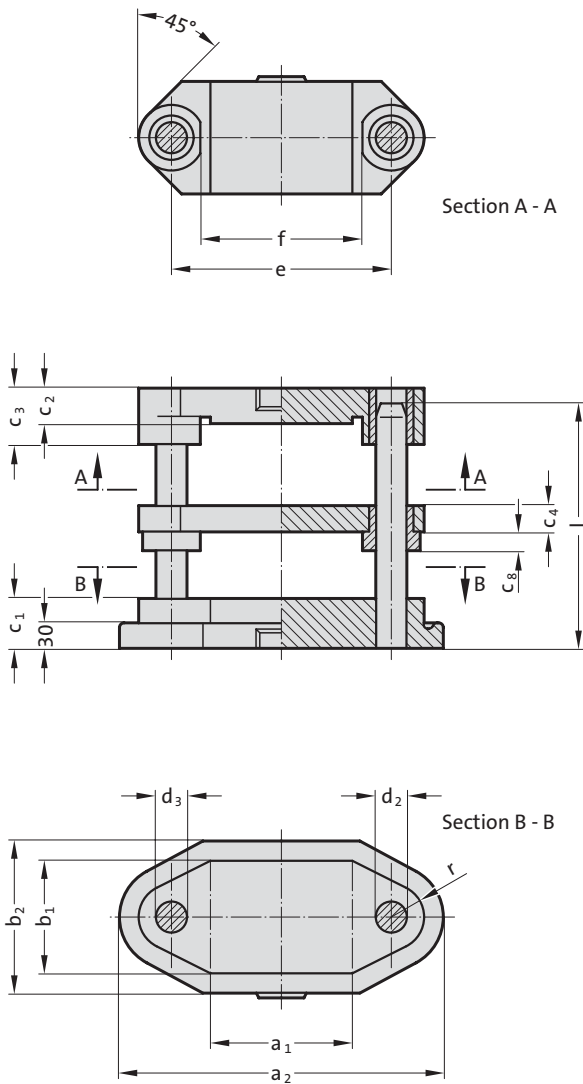

Guide Elements

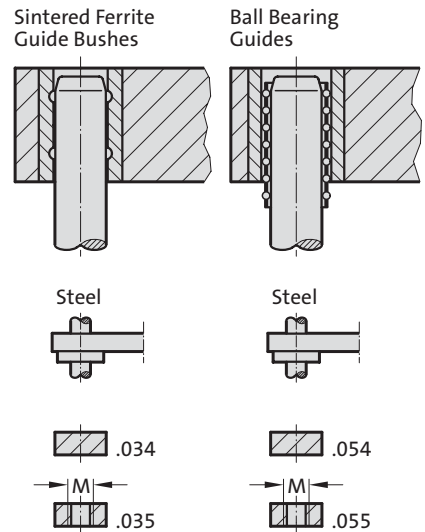

Stripper

Order No (part II)
Available without or
with shank thread
in top bolster

201.13. Die set DIN 9814 Shape C/CG

| Order No part 1* | Work area | | | | | | | | | | | | | |
|------------------|---------------------------------|----------------|----------------|----------------|----------------|----------------|----------------|----------------|----------------|----------------|-----|-----|----|--------|
| | a ₁ x b ₁ | a ₂ | b ₂ | c ₁ | c ₂ | c ₃ | c ₄ | c ₈ | d ₂ | d ₃ | e | l | r | M |
| 201.13.080.063. | 80 x 63 | 235 | 103 | 50 | 30 | 50 | 18 | 14 | 20 | 19 | 140 | 160 | 27 | 20x1.5 |
| 201.13.100.080. | 100 x 80 | 265 | 120 | 50 | 30 | 50 | 22 | 18 | 25 | 24 | 165 | 160 | 30 | 20x1.5 |
| 201.13.125.100. | 125 x 100 | 290 | 140 | 50 | 40 | 60 | 22 | 18 | 25 | 24 | 190 | 160 | 30 | 24x1.5 |
| 201.13.160.125. | 160 x 125 | 355 | 165 | 56 | 40 | 60 | 27 | 18 | 32 | 30 | 240 | 180 | 37 | 24x1.5 |
| 201.13.200.160. | 200 x 160 | 395 | 200 | 56 | 50 | 70 | 27 | 18 | 32 | 30 | 280 | 200 | 37 | 30x2 |

*Order No Part 2 = complete guide type

Ordering Code (example):

| | | |
|-----------------------------|------------------|------------------------|
| Die set DIN 9814 Shape C/CG | | =201.13. |
| Working area length A1 | 80 mm | = 080. |
| Working area width B1 | 63 mm | = 063. |
| Type of guides FA | Sintered ferrite | = 03 |
| Shank thread ZG | without | = 4 |
| Order No | | =201.13.080. 063. 03 4 |

Die set DIN 9819 Shape C/CG

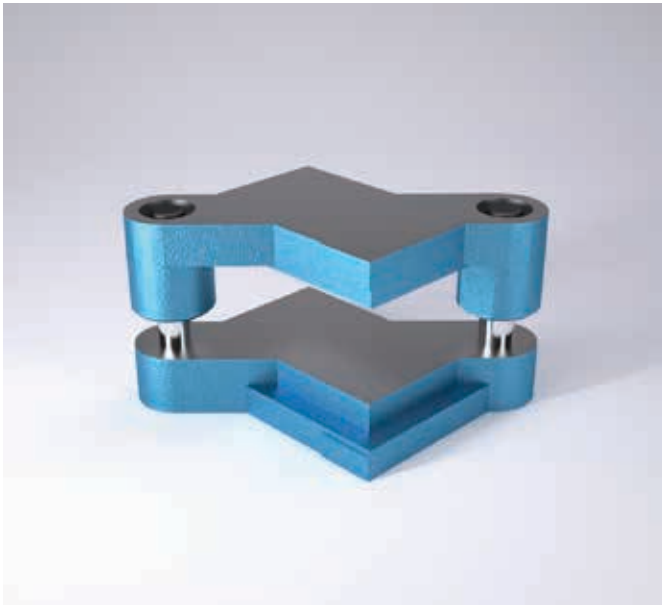

201.21.

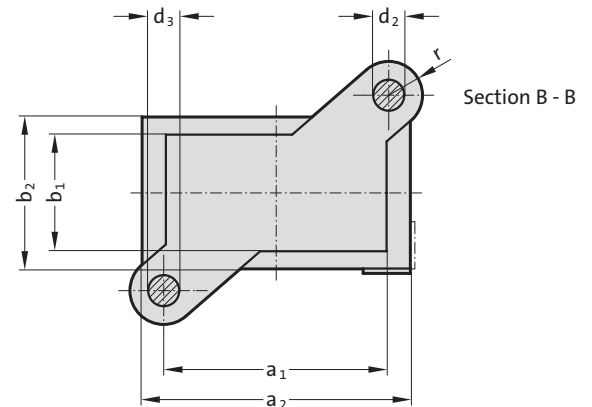
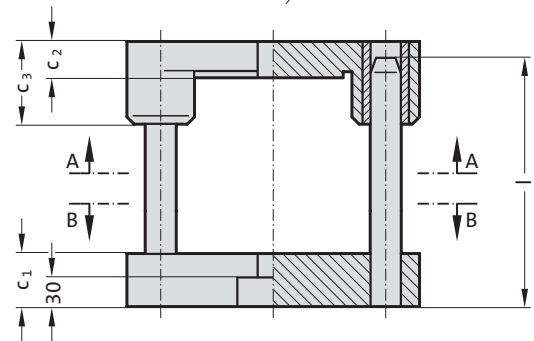
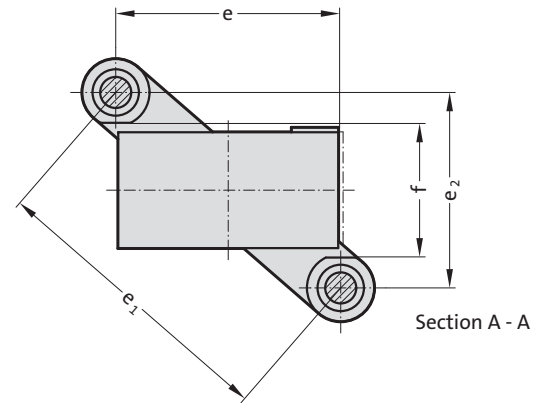

Guide Elements

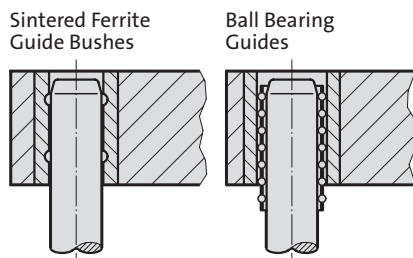

Order No (part II)
Available without or
with shank thread
in top bolster

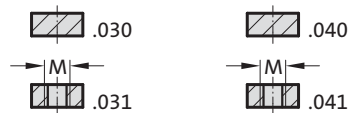

201.21. Die set DIN 9819 Shape C/CG

| Order No part 1* | Work area | | | | | | | | | | | | | | |
|------------------|---------------------------------|----------------|----------------|----------------|----------------|----------------|----------------|----------------|-----|----------------|----------------|-----|-----|----|--------|
| | a ₁ x b ₁ | a ₂ | b ₂ | c ₁ | c ₂ | c ₃ | d ₂ | d ₃ | e | e ₁ | e ₂ | f | l | r | M |
| 201.21.080.063. | 80 x 63 | 120 | 103 | 50 | 30 | 80 | 20 | 19 | 80 | 145 | 121 | 73 | 160 | 27 | 20x1.5 |
| 201.21.100.063. | 100 x 63 | 140 | 103 | 50 | 30 | 80 | 20 | 19 | 100 | 157 | 121 | 73 | 160 | 27 | 20x1.5 |
| 201.21.100.080. | 100 x 80 | 140 | 120 | 50 | 30 | 80 | 25 | 24 | 100 | 175 | 144 | 90 | 160 | 30 | 20x1.5 |
| 201.21.125.080. | 125 x 80 | 165 | 120 | 50 | 30 | 80 | 25 | 24 | 125 | 191 | 144 | 90 | 160 | 30 | 20x1.5 |
| 201.21.125.100. | 125 x 100 | 165 | 140 | 50 | 40 | 90 | 25 | 24 | 125 | 206 | 164 | 110 | 160 | 30 | 24x1.5 |
| 201.21.160.100. | 160 x 100 | 200 | 140 | 50 | 40 | 90 | 25 | 24 | 160 | 229 | 164 | 110 | 160 | 30 | 24x1.5 |
| 201.21.200.100. | 200 x 100 | 240 | 140 | 56 | 40 | 90 | 32 | 30 | 200 | 268 | 179 | 110 | 180 | 37 | 24x1.5 |
| 201.21.160.125. | 160 x 125 | 200 | 165 | 56 | 40 | 90 | 32 | 30 | 160 | 259 | 204 | 139 | 180 | 37 | 24x1.5 |
| 201.21.200.125. | 200 x 125 | 240 | 165 | 56 | 40 | 90 | 32 | 30 | 200 | 286 | 204 | 139 | 180 | 37 | 24x1.5 |
| 201.21.250.125. | 250 x 125 | 290 | 165 | 56 | 40 | 90 | 32 | 30 | 250 | 323 | 204 | 139 | 180 | 37 | 24x1.5 |
| 201.21.315.125. | 315 x 125 | 355 | 165 | 56 | 40 | 90 | 32 | 30 | 315 | 375 | 204 | 139 | 180 | 37 | 24x1.5 |
| 201.21.200.160. | 200 x 160 | 240 | 200 | 56 | 50 | 100 | 32 | 30 | 200 | 312 | 240 | 174 | 200 | 37 | 30x2 |
| 201.21.250.160. | 250 x 160 | 290 | 200 | 56 | 50 | 100 | 32 | 30 | 250 | 346 | 240 | 174 | 200 | 37 | 30x2 |
| 201.21.250.200. | 250 x 200 | 300 | 250 | 63 | 50 | 100 | 40 | 38 | 250 | 392 | 302 | 218 | 224 | 48 | 30x2 |
| 201.21.315.200. | 315 x 200 | 365 | 250 | 63 | 50 | 100 | 40 | 38 | 315 | 436 | 302 | 218 | 224 | 48 | 30x2 |
| 201.21.315.250. | 315 x 250 | 365 | 300 | 63 | 50 | 100 | 40 | 38 | 315 | 472 | 352 | 268 | 224 | 48 | 30x2 |

*Order No Part 2 = complete guide type

Die set



201.23.

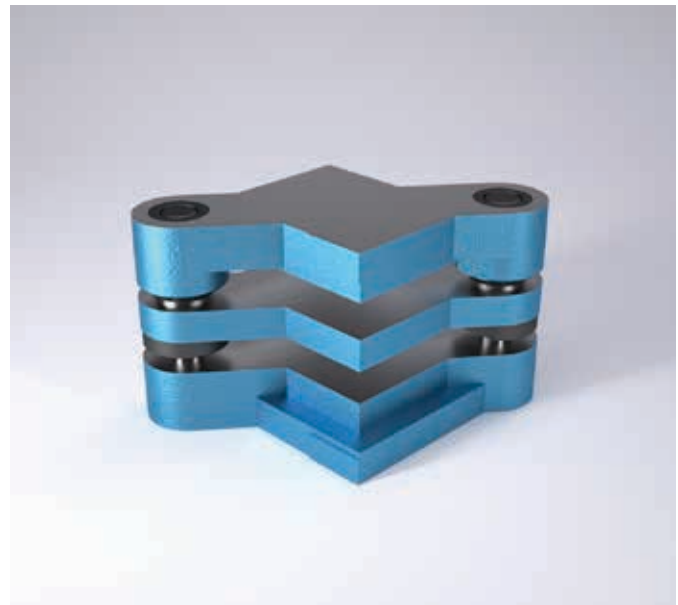
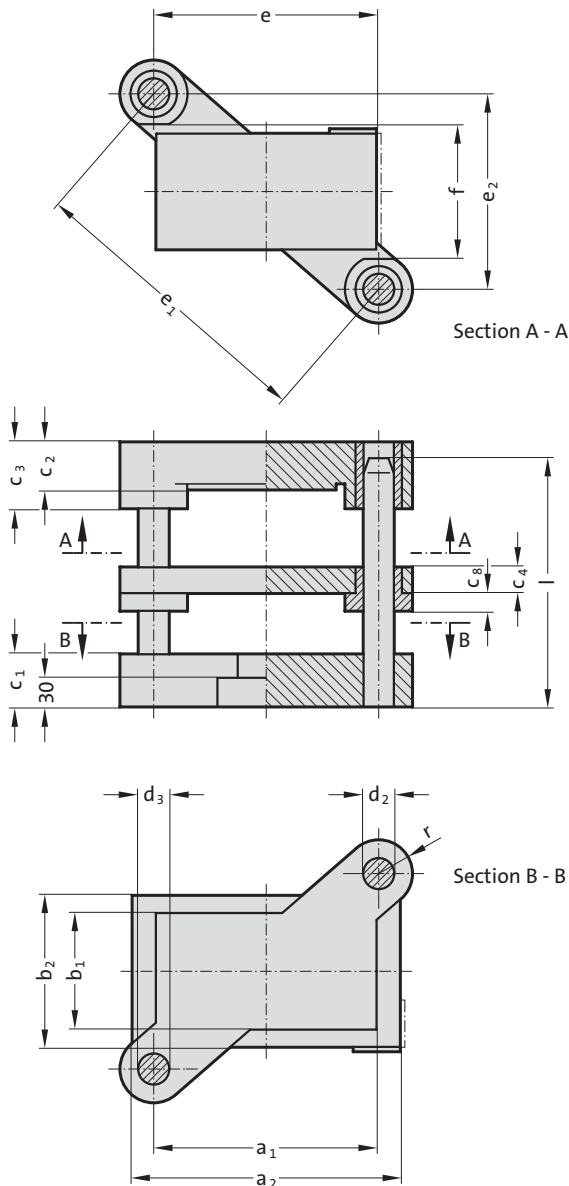

Guide Elements

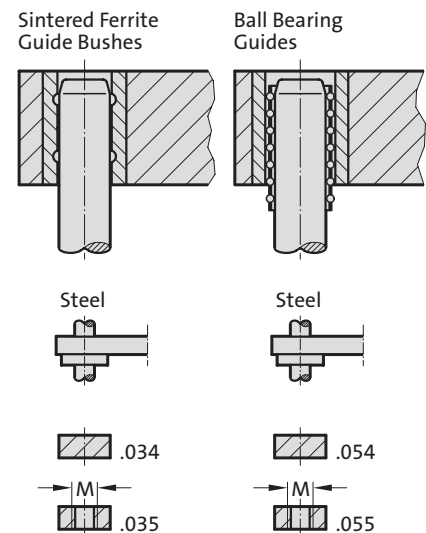

Stripper

Order No (part II)
Available without or
with shank thread
in top bolster

201.23. Die set

| Order No part 1* | Work area | | | | | | | | | | | | | | | | |
|------------------|---------------------------------|----------------|----------------|----------------|----------------|----------------|----------------|----------------|----------------|----------------|-----|----------------|----------------|-----|-----|----|--------|
| | a ₁ x b ₁ | a ₂ | b ₂ | c ₁ | c ₂ | c ₃ | c ₄ | c ₈ | d ₂ | d ₃ | e | e ₁ | e ₂ | f | l | r | M |
| 201.23.100.080. | 100 x 80 | 140 | 120 | 50 | 30 | 50 | 22 | 15 | 25 | 24 | 100 | 175 | 144 | 98 | 160 | 30 | 20x1.5 |
| 201.23.125.100. | 125 x 100 | 165 | 140 | 50 | 40 | 60 | 22 | 15 | 25 | 24 | 125 | 206 | 164 | 118 | 160 | 30 | 24x1.5 |
| 201.23.160.100. | 160 x 100 | 200 | 140 | 50 | 40 | 60 | 22 | 15 | 25 | 24 | 160 | 229 | 164 | 118 | 160 | 30 | 24x1.5 |
| 201.23.160.125. | 160 x 125 | 200 | 165 | 56 | 40 | 60 | 27 | 15 | 32 | 30 | 160 | 259 | 204 | 148 | 180 | 37 | 24x1.5 |
| 201.23.200.125. | 200 x 125 | 240 | 165 | 56 | 40 | 60 | 27 | 15 | 32 | 30 | 200 | 286 | 204 | 148 | 180 | 37 | 24x1.5 |
| 201.23.250.160. | 250 x 160 | 290 | 200 | 56 | 50 | 70 | 27 | 15 | 32 | 30 | 250 | 346 | 240 | 184 | 200 | 37 | 30x2 |

*Order No Part 2 = complete guide type

Ordering Code (example):

| | | | |
|------------------------|------------------|---|------------------------|
| Die set | | = | 201.23. |
| Working area length A1 | 100 mm | = | 100. |
| Working area width B1 | 80 mm | = | 080. |
| Type of guides FA | Sintered ferrite | = | 03 |
| Shank thread ZG | without | = | 4 |
| Order No | | = | 201.23. 100. 080. 03 4 |



201.26.

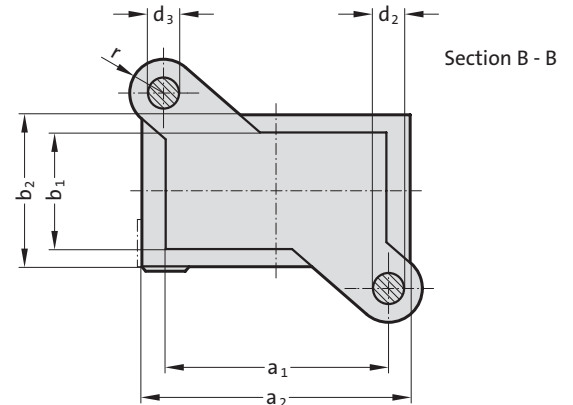
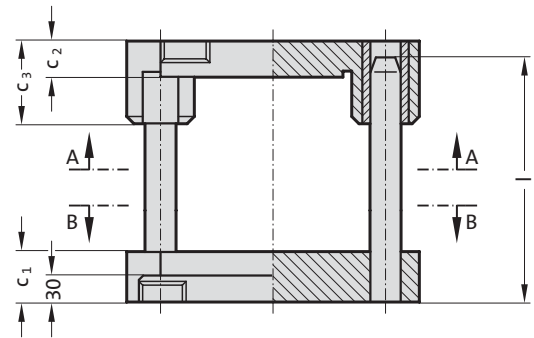
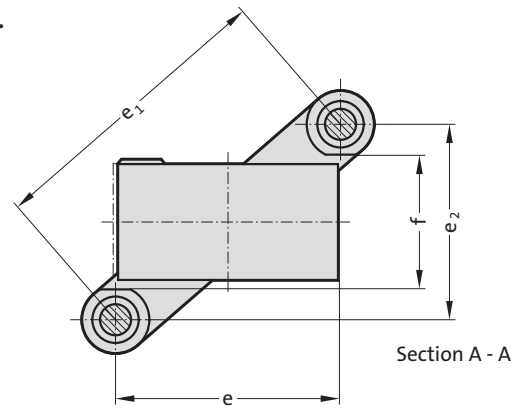

Guide Elements

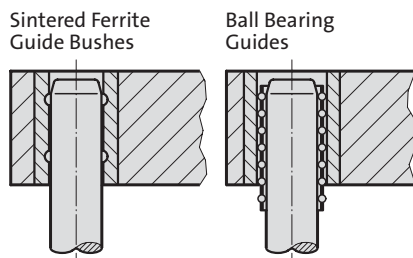

Order No (part II)
Available without or
with shank thread
in top bolster

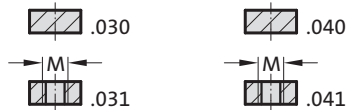

201.26. Die set

| Order No part 1* | Work area | | | | | | | | | | | | | | | |
|------------------|---------------------------------|----------------|----------------|----------------|----------------|----------------|----------------|----------------|-----|----------------|----------------|-----|-----|----|--------|--|
| | a ₁ x b ₁ | a ₂ | b ₂ | c ₁ | c ₂ | c ₃ | d ₂ | d ₃ | e | e ₁ | e ₂ | f | l | r | M | |
| 201.26.125.100. | 125 x 100 | 165 | 140 | 50 | 40 | 90 | 25 | 24 | 125 | 206 | 164 | 110 | 160 | 30 | 24x1.5 | |
| 201.26.160.100. | 160 x 100 | 200 | 140 | 50 | 40 | 90 | 25 | 24 | 160 | 229 | 164 | 110 | 160 | 30 | 24x1.5 | |
| 201.26.160.125. | 160 x 125 | 200 | 165 | 56 | 40 | 90 | 32 | 30 | 160 | 259 | 204 | 139 | 180 | 37 | 24x1.5 | |
| 201.26.200.125. | 200 x 125 | 240 | 165 | 56 | 40 | 90 | 32 | 30 | 200 | 286 | 204 | 139 | 180 | 37 | 24x1.5 | |
| 201.26.200.160. | 200 x 160 | 240 | 200 | 56 | 50 | 100 | 32 | 30 | 200 | 312 | 240 | 174 | 200 | 37 | 30x2 | |

*Order No Part 2 = complete guide type

Ordering Code (example):

| | | |
|------------------------|------------------|--------------------------|
| Die set | | = 201.26. |
| Working area length A1 | 125 mm | = 125. |
| Working area width B1 | 100 mm | = 100. |
| Type of guides FA | Sintered ferrite | = 03 |
| Shank thread ZG | without | = 0 |
| Order No | | = 201.26. 125. 100. 03 0 |

Die set DIN 9822 Shape C



201.31.

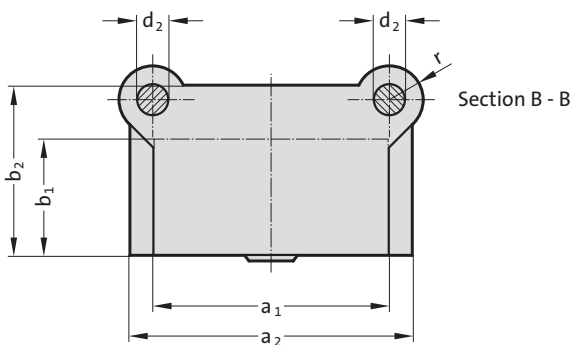
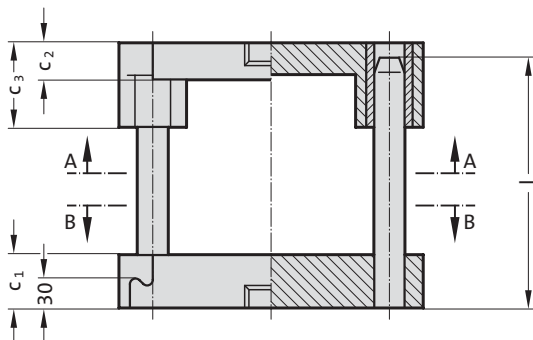
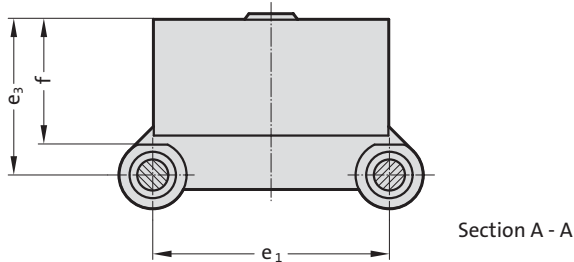

Guide Elements

Sintered Ferrite Guide Bushes

Ball Bearing Guides

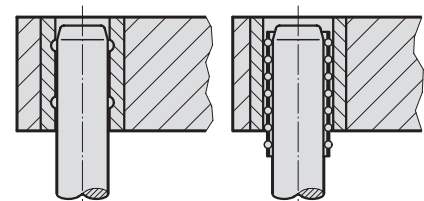

Order No (part II)
Without shank thread
in top bolster



201.31. Die set DIN 9822 Shape C

| Order No part 1* | Work area | | | | | | | | | | | | |
|------------------|------------------|-------|-------|-------|-------|-------|-------|-------|-------|-----|-----|-----|--|
| | $a_1 \times b_1$ | a_2 | b_2 | c_1 | c_2 | c_3 | d_2 | e_1 | e_3 | f | l | r | |
| 201.31.063.050. | 63 x 50 | 95 | 84 | 40 | 25 | 50 | 20 | 72 | 77 | 55 | 140 | 22 | |
| 201.31.080.063. | 80 x 63 | 125 | 105 | 45 | 30 | 60 | 20 | 80 | 92 | 68 | 160 | 27 | |
| 201.31.100.063. | 100 x 63 | 145 | 105 | 45 | 30 | 60 | 20 | 100 | 92 | 68 | 160 | 27 | |
| 201.31.100.080. | 100 x 80 | 145 | 130 | 50 | 30 | 70 | 25 | 100 | 112 | 87 | 160 | 30 | |
| 201.31.125.080. | 125 x 80 | 170 | 130 | 50 | 30 | 70 | 25 | 125 | 112 | 87 | 160 | 30 | |
| 201.31.160.080. | 160 x 80 | 205 | 130 | 50 | 30 | 70 | 25 | 160 | 112 | 87 | 160 | 30 | |
| 201.31.125.100. | 125 x 100 | 170 | 150 | 56 | 40 | 90 | 32 | 125 | 140 | 107 | 180 | 37 | |
| 201.31.160.100. | 160 x 100 | 205 | 150 | 56 | 40 | 90 | 32 | 160 | 140 | 107 | 180 | 37 | |
| 201.31.200.100. | 200 x 100 | 245 | 150 | 56 | 40 | 90 | 32 | 200 | 140 | 107 | 180 | 37 | |
| 201.31.160.125. | 160 x 125 | 215 | 180 | 56 | 40 | 90 | 32 | 160 | 165 | 132 | 180 | 37 | |
| 201.31.200.125. | 200 x 125 | 255 | 180 | 56 | 40 | 90 | 32 | 200 | 165 | 132 | 180 | 37 | |
| 201.31.250.125. | 250 x 125 | 305 | 180 | 56 | 40 | 90 | 32 | 250 | 165 | 132 | 180 | 37 | |
| 201.31.200.160. | 200 x 160 | 255 | 225 | 63 | 50 | 120 | 40 | 200 | 210 | 167 | 224 | 48 | |
| 201.31.250.160. | 250 x 160 | 305 | 225 | 63 | 50 | 120 | 40 | 250 | 210 | 167 | 224 | 48 | |
| 201.31.250.200. | 250 x 200 | 305 | 270 | 63 | 50 | 120 | 50 | 250 | 260 | 207 | 224 | 56 | |
| 201.31.315.250. | 315 x 250 | 370 | 320 | 63 | 50 | 120 | 50 | 315 | 310 | 257 | 224 | 56 | |

*Order No Part 2 = complete guide type

Die set

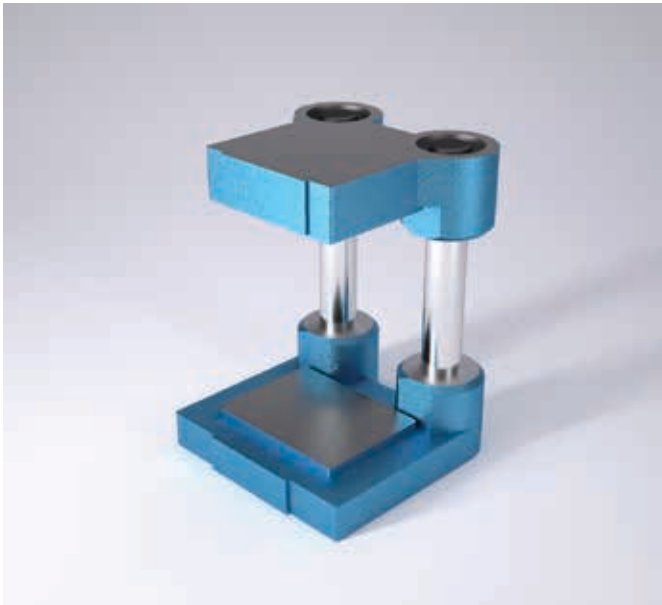

201.33.

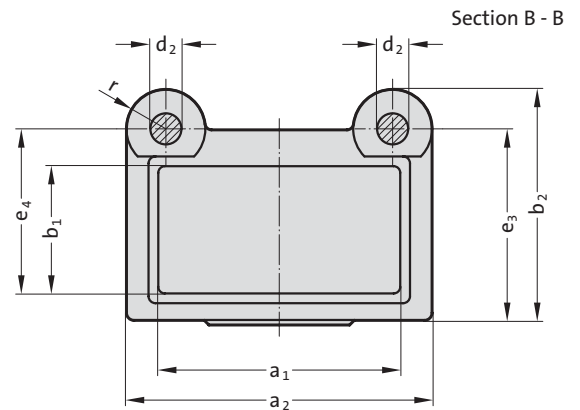
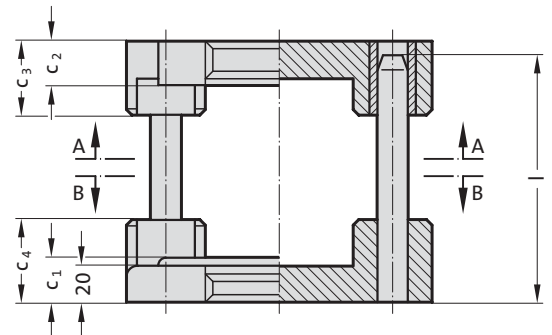
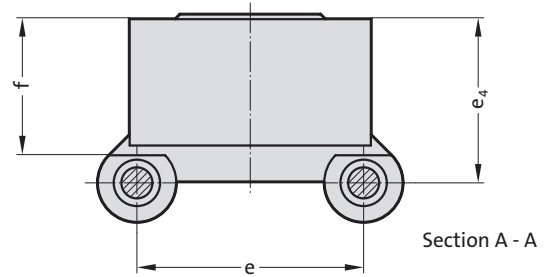

Guide Elements

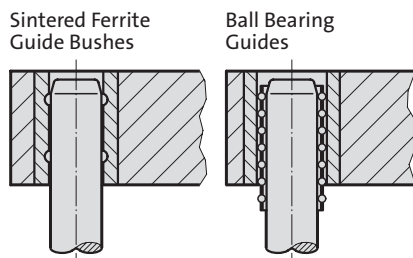

Order No (part II)
Without shank thread
in top bolster



201.33. Die set

| Order No part 1* | Work area | | b ₂ | c ₁ | c ₂ | c ₃ | c ₄ | d ₂ | e | e ₃ | e ₄ | f | l | r |
|------------------|---------------------------------|----------------|----------------|----------------|----------------|----------------|----------------|----------------|----|----------------|----------------|----|-----|----|
| | a ₁ x b ₁ | a ₂ | | | | | | | | | | | | |
| 201.33.063.050. | 63 x 50 | 116 | 110 | 25 | 25 | 40 | 45 | 16 | 72 | 88 | 74 | 57 | 125 | 22 |
| 201.33.080.060. | 80 x 60 | 116 | 117 | 25 | 25 | 40 | 45 | 20 | 72 | 95 | 81 | 62 | 160 | 22 |

*Order No Part 2 = complete guide type

Ordering Code (example):

| | | |
|------------------------|------------------|-------------------------|
| Die set | | = 201.33. |
| Working area length A1 | 63 mm | = 063. |
| Working area width B1 | 50 mm | = 050. |
| Type of guides FA | Sintered ferrite | = 030 |
| Order No | | = 201.33. 063. 050. 030 |

Die set



201.36.

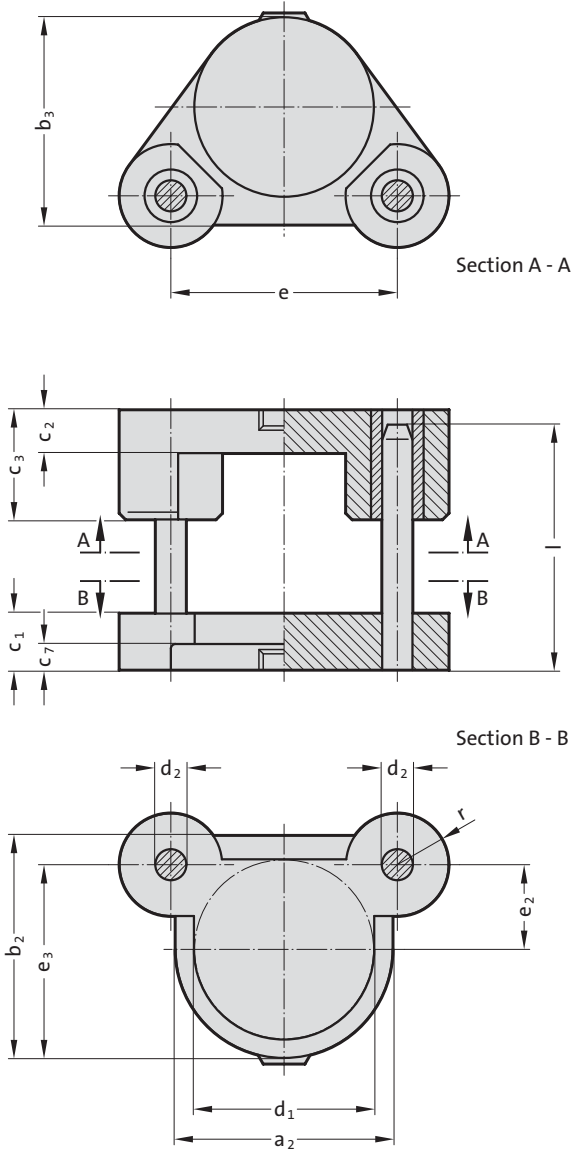

Guide Elements

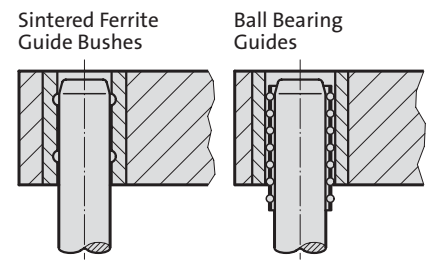

Order No (part II)
Without shank thread
in top bolster



201.36. Die set

| Order No part 1* | Work area | | | | | | | | | | | | | | |
|------------------|----------------|----------------|----------------|----------------|----------------|----------------|----------------|----------------|----------------|-----|----------------|----------------|-----|----|--|
| | d ₁ | a ₂ | b ₂ | b ₃ | c ₁ | c ₂ | c ₃ | c ₇ | d ₂ | e | e ₂ | e ₃ | l | r | |
| 201.36.050. | 50 | 80 | 80 | 65 | 40 | 30 | 50 | 25 | 20 | 66 | 33 | 73 | 125 | 20 | |
| 201.36.063. | 63 | 94 | 94 | 78 | 45 | 30 | 60 | 25 | 20 | 82 | 41 | 88 | 125 | 25 | |
| 201.36.080. | 80 | 110 | 110 | 95 | 50 | 30 | 70 | 30 | 25 | 105 | 52 | 107 | 160 | 30 | |
| 201.36.100. | 100 | 140 | 140 | 120 | 50 | 30 | 70 | 30 | 25 | 125 | 57 | 127 | 160 | 30 | |
| 201.36.125. | 125 | 166 | 166 | 145 | 56 | 40 | 90 | 30 | 32 | 157 | 73 | 156 | 180 | 38 | |
| 201.36.160. | 160 | 200 | 200 | 180 | 63 | 50 | 120 | 30 | 40 | 200 | 85 | 185 | 224 | 48 | |
| 201.36.180. | 180 | 220 | 220 | 200 | 63 | 50 | 120 | 30 | 40 | 224 | 90 | 200 | 224 | 48 | |
| 201.36.200. | 200 | 250 | 250 | 225 | 63 | 50 | 120 | 30 | 50 | 250 | 95 | 220 | 224 | 56 | |
| 201.36.250. | 250 | 300 | 300 | 275 | 63 | 50 | 120 | 30 | 50 | 300 | 120 | 270 | 224 | 56 | |

*Order No Part 2 = complete guide type

Ordering Code (example):

| | | |
|-------------------|------------------|-------------------|
| Die set | | =201.36. |
| Work area D1 | 50 mm | = 050. |
| Type of guides FA | Sintered ferrite | = 030 |
| Order No | | =201.36. 050. 030 |

Fine blanking die set

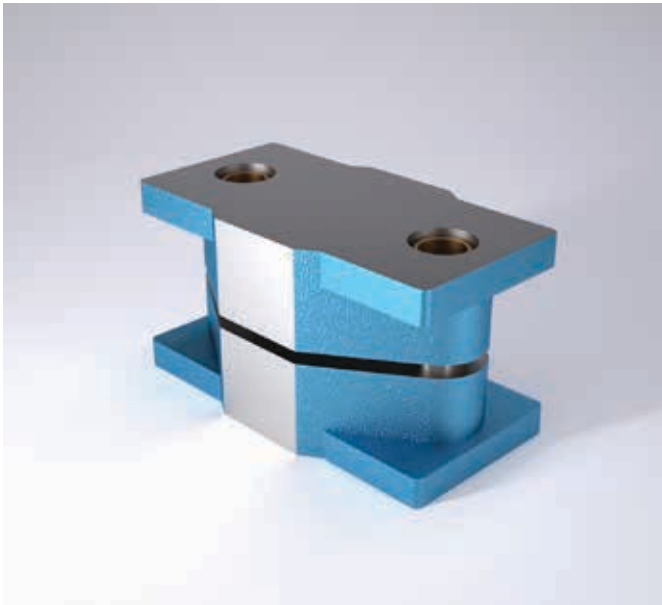

Guide Elements

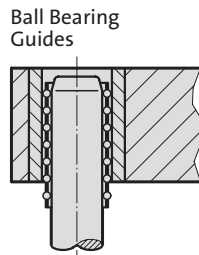

201.39.

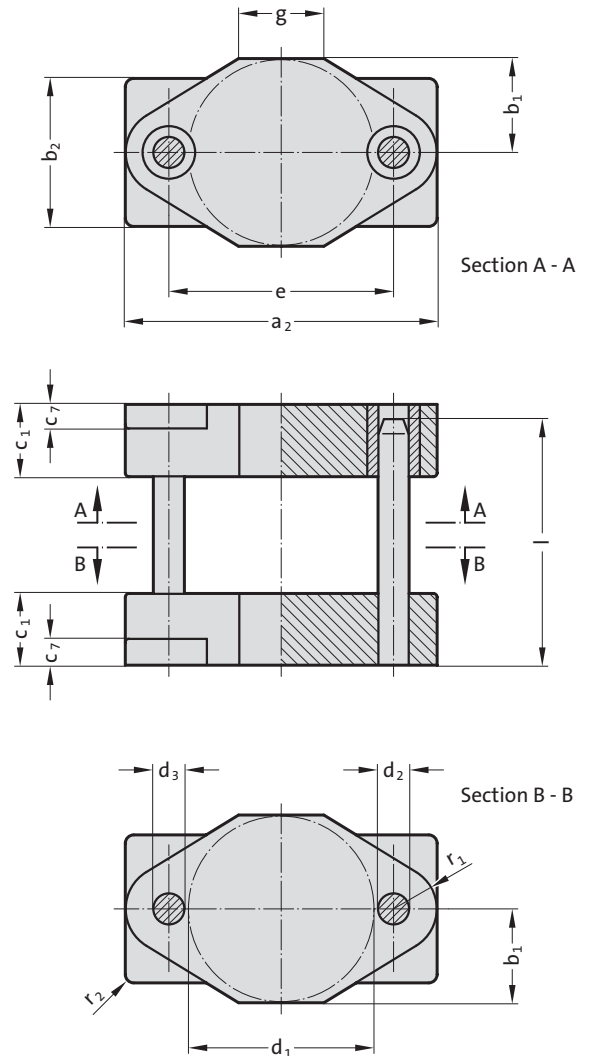

Faces front and rear fine machined after assembly – their perfect alignment permits use as datum reference.

201.39. Fine blanking die set

| Order No | Work area | | | | | | | | | | | | |
|----------------|-----------|-------|-------|-------|-------|-------|-------|-------|-----|-----|-----|-------|-------|
| | d_1 | a_2 | b_1 | b_2 | c_1 | c_7 | d_2 | d_3 | G | e | l | r_1 | r_2 |
| 201.39.100.040 | 100 | 220 | 50 | 85 | 75 | 22 | 25 | 24 | 60 | 140 | 140 | 27 | 6 |
| 201.39.125.040 | 125 | 245 | 62 | 100 | 75 | 25 | 25 | 24 | 80 | 165 | 140 | 27 | 6 |
| 201.39.160.040 | 160 | 290 | 80 | 140 | 75 | 25 | 32 | 30 | 80 | 200 | 140 | 35 | 6 |
| 201.39.200.040 | 200 | 340 | 100 | 160 | 80 | 30 | 40 | 38 | 90 | 250 | 160 | 45 | 8 |
| 201.39.250.040 | 250 | 400 | 125 | 200 | 85 | 32 | 40 | 38 | 100 | 300 | 180 | 50 | 10 |



All-Steel- and Aluminium Die Sets



Die set without stripper ~DIN 9868/ISO 11415

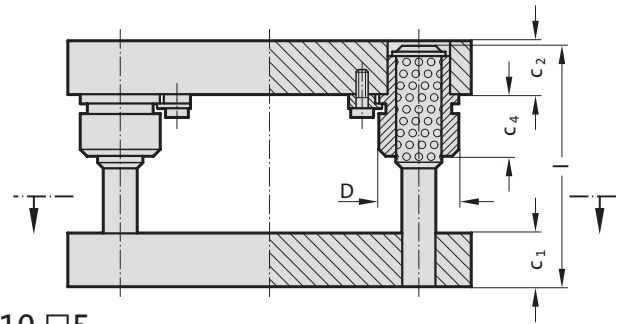

2010.□5.

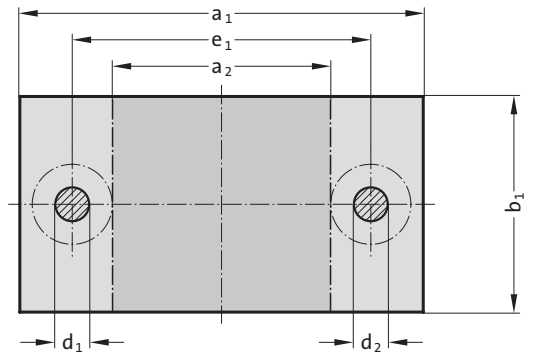

2010.□6.

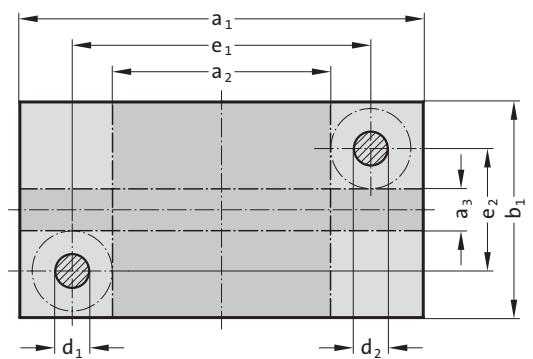

2010.□7.

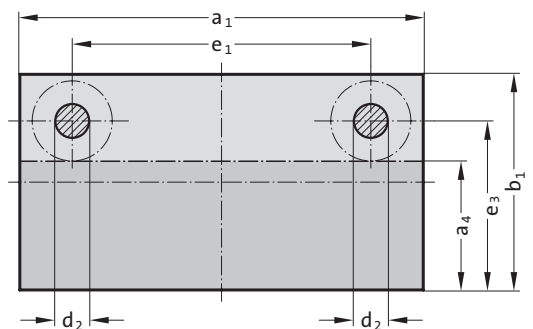

2010.□9.

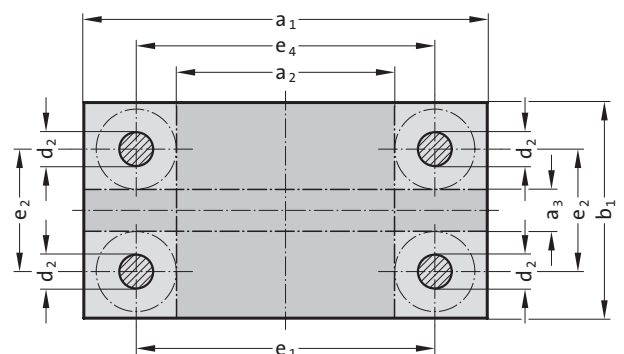

Standard Guide Systems

Headed Sintered Ferrite Bushes, carbonitrided = .834.

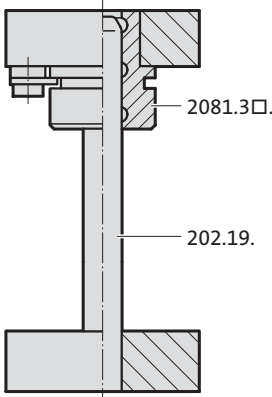

Headed Ball Bearing Bushes = .862.

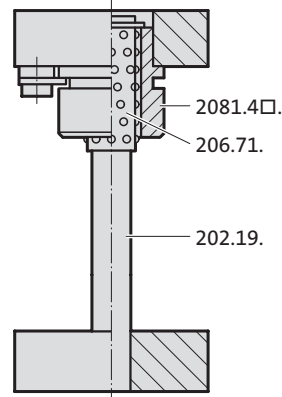

Description:

FIBRO Die Sets offer the choice between sintered ferrite sliding guides and those of the ball bearing type to DIN-ISO. Both come with headed guide bushes. These are seated in push-fit bolster bores and retained there by screw clamps.



Execution:

Steel: External contours milled, thickness surfaces ground
 a_1 or $b_1 \leq 630 = +0,2/+0,4$
 a_1 or $b_1 > 630 = +0,2/+0,6$

Aluminium: External contours sawed, thickness surfaces ground
 a_1 or $b_1 = +1/+4$

Advisory: Ordering Code:

Hole pattern for the screw clamps depends on positioning of working surface, determined by last part of the Order No,

for example: 2010.49.2520.4.862.1  lengthwise
 .2  across

Note:

On request, Standard Die Sets can also be fitted with any other FIBRO Guide Elements (see die sets to customers' drawings). FIBRO will furthermore supply die sets with special machining features.



Die set without stripper ~DIN 9868/ISO 11415

2010. □□ .

Ordering Code (principle):

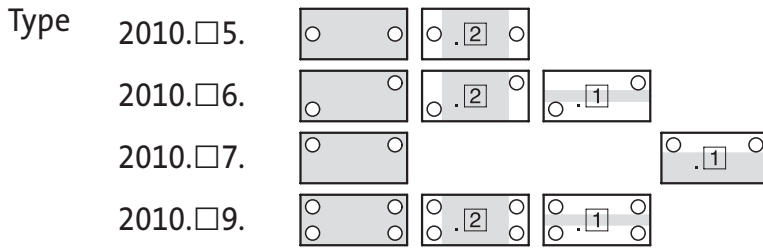

2010 . 4 5 . 4025 . 1 . 862 . 2

- Position of work area: 2
- Guide system: Headed ball bearing bushes
- Thickness combinations P: C₁ - C₂
- External dimensions: a₁ = 400 × b₁ = 250
- Type: Position of guide elements
- Material: 4 = Steel, 6 = Aluminium
- Standard Die sets

| Order No. | external dimensions a ₁ × b ₁ | work area across a ₂ × b ₁ | work area lengthwise a ₁ × a ₃ | work area lengthwise a ₁ × a ₄ | C ₁₊₂ | C ₂₊₂ | C ₄ S | C ₄ K | d ₁ /d ₂ × l | D | e ₁ | e ₂ | e ₃ | e ₄ |
|--------------|---|--|--|--|------------------|------------------|------------------|------------------|------------------------------------|----|----------------|----------------|----------------|----------------|
| 2010.1608.1. | 160 × 80 | 60 × 80 | - | - | 32 | 32 | 20 | 36 | 19/20 × 160 | 39 | 100 | - | - | - |
| 2010.1610.1. | 160 × 100 | 60 × 100 | - | 160 × 50 | 32 | 32 | 20 | 36 | 19/20 × 160 | 39 | 100 | - | 70 | - |
| 2010.1612.1. | 160 × 125 | 60 × 125 | - | 160 × 75 | 32 | 32 | 20 | 36 | 19/20 × 160 | 39 | 100 | - | 95 | - |
| 2010.1616.1. | 160 × 160 | 60 × 160 | 160 × 60 | 160 × 110 | 32 | 32 | 20 | 36 | 19/20 × 160 | 39 | 100 | 100 | 130 | 103 |
| 2010.2010.1. | 200 × 100 | 70 × 100 | - | - | 40 | 40 | 36 | 56 | 24/25 × 180 | 46 | 120 | - | - | - |
| 2010.2010.2. | 200 × 100 | 70 × 100 | - | - | 40 | 32 | 36 | 56 | 24/25 × 180 | 46 | 120 | - | - | - |
| 2010.2010.3. | 200 × 100 | 70 × 100 | - | - | 32 | 40 | 36 | 56 | 24/25 × 180 | 46 | 120 | - | - | - |
| 2010.2010.4. | 200 × 100 | 70 × 100 | - | - | 32 | 32 | 36 | 56 | 24/25 × 180 | 46 | 120 | - | - | - |
| 2010.2012.1. | 200 × 125 | 70 × 125 | - | 200 × 60 | 40 | 40 | 36 | 56 | 24/25 × 180 | 46 | 120 | - | 85 | - |
| 2010.2012.2. | 200 × 125 | 70 × 125 | - | 200 × 60 | 40 | 32 | 36 | 56 | 24/25 × 180 | 46 | 120 | - | 85 | - |
| 2010.2012.3. | 200 × 125 | 70 × 125 | - | 200 × 60 | 32 | 40 | 36 | 56 | 24/25 × 180 | 46 | 120 | - | 85 | - |
| 2010.2012.4. | 200 × 125 | 70 × 125 | - | 200 × 60 | 32 | 32 | 36 | 56 | 24/25 × 180 | 46 | 120 | - | 85 | - |
| 2010.2016.1. | 200 × 160 | 70 × 160 | - | 200 × 95 | 40 | 40 | 36 | 56 | 24/25 × 180 | 46 | 120 | - | 120 | - |
| 2010.2016.2. | 200 × 160 | 70 × 160 | - | 200 × 95 | 40 | 32 | 36 | 56 | 24/25 × 180 | 46 | 120 | - | 120 | - |
| 2010.2016.3. | 200 × 160 | 70 × 160 | - | 200 × 95 | 32 | 40 | 36 | 56 | 24/25 × 180 | 46 | 120 | - | 120 | - |
| 2010.2016.4. | 200 × 160 | 70 × 160 | - | 200 × 95 | 32 | 32 | 36 | 56 | 24/25 × 180 | 46 | 120 | - | 120 | - |
| 2010.2020.1. | 200 × 200 | 70 × 200 | 200 × 70 | 200 × 135 | 40 | 40 | 36 | 56 | 24/25 × 180 | 46 | 120 | 120 | 160 | 123 |
| 2010.2020.2. | 200 × 200 | 70 × 200 | 200 × 70 | 200 × 135 | 40 | 32 | 36 | 56 | 24/25 × 180 | 46 | 120 | 120 | 160 | 123 |
| 2010.2020.3. | 200 × 200 | 70 × 200 | 200 × 70 | 200 × 135 | 32 | 40 | 36 | 56 | 24/25 × 180 | 46 | 120 | 120 | 160 | 123 |
| 2010.2020.4. | 200 × 200 | 70 × 200 | 200 × 70 | 200 × 135 | 32 | 32 | 36 | 56 | 24/25 × 180 | 46 | 120 | 120 | 160 | 123 |
| 2010.2512.1. | 250 × 125 | 120 × 125 | - | 250 × 60 | 40 | 40 | 36 | 56 | 24/25 × 180 | 46 | 170 | - | 85 | - |
| 2010.2512.2. | 250 × 125 | 120 × 125 | - | 250 × 60 | 40 | 32 | 36 | 56 | 24/25 × 180 | 46 | 170 | - | 85 | - |
| 2010.2512.3. | 250 × 125 | 120 × 125 | - | 250 × 60 | 32 | 40 | 36 | 56 | 24/25 × 180 | 46 | 170 | - | 85 | - |
| 2010.2512.4. | 250 × 125 | 120 × 125 | - | 250 × 60 | 32 | 32 | 36 | 56 | 24/25 × 180 | 46 | 170 | - | 85 | - |
| 2010.2516.1. | 250 × 160 | 120 × 160 | - | 250 × 95 | 40 | 40 | 36 | 56 | 24/25 × 180 | 46 | 170 | - | 120 | - |
| 2010.2516.2. | 250 × 160 | 120 × 160 | - | 250 × 95 | 40 | 32 | 36 | 56 | 24/25 × 180 | 46 | 170 | - | 120 | - |
| 2010.2516.3. | 250 × 160 | 120 × 160 | - | 250 × 95 | 32 | 40 | 36 | 56 | 24/25 × 180 | 46 | 170 | - | 120 | - |
| 2010.2516.4. | 250 × 160 | 120 × 160 | - | 250 × 95 | 32 | 32 | 36 | 56 | 24/25 × 180 | 46 | 170 | - | 120 | - |
| 2010.2520.1. | 250 × 200 | 120 × 200 | 250 × 70 | 250 × 135 | 40 | 40 | 36 | 56 | 24/25 × 180 | 46 | 170 | 120 | 160 | 173 |
| 2010.2520.2. | 250 × 200 | 120 × 200 | 250 × 70 | 250 × 135 | 40 | 32 | 36 | 56 | 24/25 × 180 | 46 | 170 | 120 | 160 | 173 |
| 2010.2520.3. | 250 × 200 | 120 × 200 | 250 × 70 | 250 × 135 | 32 | 40 | 36 | 56 | 24/25 × 180 | 46 | 170 | 120 | 160 | 173 |
| 2010.2520.4. | 250 × 200 | 120 × 200 | 250 × 70 | 250 × 135 | 32 | 32 | 36 | 56 | 24/25 × 180 | 46 | 170 | 120 | 160 | 173 |
| 2010.2525.1. | 250 × 250 | 120 × 250 | 250 × 120 | 250 × 185 | 40 | 40 | 36 | 56 | 24/25 × 180 | 46 | 170 | 170 | 210 | 173 |
| 2010.2525.2. | 250 × 250 | 120 × 250 | 250 × 120 | 250 × 185 | 40 | 32 | 36 | 56 | 24/25 × 180 | 46 | 170 | 170 | 210 | 173 |
| 2010.2525.3. | 250 × 250 | 120 × 250 | 250 × 120 | 250 × 185 | 32 | 40 | 36 | 56 | 24/25 × 180 | 46 | 170 | 170 | 210 | 173 |
| 2010.2525.4. | 250 × 250 | 120 × 250 | 250 × 120 | 250 × 185 | 32 | 32 | 36 | 56 | 24/25 × 180 | 46 | 170 | 170 | 210 | 173 |
| 2010.3116.1. | 315 × 160 | 165 × 160 | - | 315 × 85 | 50 | 50 | 45 | 63 | 30/32 × 200 | 53 | 225 | - | 115 | - |
| 2010.3116.2. | 315 × 160 | 165 × 160 | - | 315 × 85 | 50 | 40 | 45 | 63 | 30/32 × 200 | 53 | 225 | - | 115 | - |
| 2010.3116.3. | 315 × 160 | 165 × 160 | - | 315 × 85 | 40 | 50 | 45 | 63 | 30/32 × 200 | 53 | 225 | - | 115 | - |
| 2010.3116.4. | 315 × 160 | 165 × 160 | - | 315 × 85 | 40 | 40 | 45 | 63 | 30/32 × 200 | 53 | 225 | - | 115 | - |
| 2010.3120.1. | 315 × 200 | 165 × 200 | 315 × 50 | 315 × 125 | 50 | 50 | 45 | 63 | 30/32 × 200 | 53 | 225 | 110 | 155 | 228 |
| 2010.3120.2. | 315 × 200 | 165 × 200 | 315 × 50 | 315 × 125 | 50 | 40 | 45 | 63 | 30/32 × 200 | 53 | 225 | 110 | 155 | 228 |
| 2010.3120.3. | 315 × 200 | 165 × 200 | 315 × 50 | 315 × 125 | 40 | 50 | 45 | 63 | 30/32 × 200 | 53 | 225 | 110 | 155 | 228 |
| 2010.3120.4. | 315 × 200 | 165 × 200 | 315 × 50 | 315 × 125 | 40 | 40 | 45 | 63 | 30/32 × 200 | 53 | 225 | 110 | 155 | 228 |
| 2010.3125.1. | 315 × 250 | 165 × 250 | 315 × 100 | 315 × 175 | 50 | 50 | 45 | 63 | 30/32 × 200 | 53 | 225 | 160 | 205 | 228 |
| 2010.3125.2. | 315 × 250 | 165 × 250 | 315 × 100 | 315 × 175 | 50 | 40 | 45 | 63 | 30/32 × 200 | 53 | 225 | 160 | 205 | 228 |
| 2010.3125.3. | 315 × 250 | 165 × 250 | 315 × 100 | 315 × 175 | 40 | 50 | 45 | 63 | 30/32 × 200 | 53 | 225 | 160 | 205 | 228 |
| 2010.3125.4. | 315 × 250 | 165 × 250 | 315 × 100 | 315 × 175 | 40 | 40 | 45 | 63 | 30/32 × 200 | 53 | 225 | 160 | 205 | 228 |
| 2010.3131.1. | 315 × 315 | 165 × 315 | 315 × 165 | 315 × 240 | 50 | 50 | 45 | 63 | 30/32 × 200 | 53 | 225 | 225 | 270 | 228 |
| 2010.3131.2. | 315 × 315 | 165 × 315 | 315 × 165 | 315 × 240 | 50 | 40 | 45 | 63 | 30/32 × 200 | 53 | 225 | 225 | 270 | 228 |
| 2010.3131.3. | 315 × 315 | 165 × 315 | 315 × 165 | 315 × 240 | 40 | 50 | 45 | 63 | 30/32 × 200 | 53 | 225 | 225 | 270 | 228 |
| 2010.3131.4. | 315 × 315 | 165 × 315 | 315 × 165 | 315 × 240 | 40 | 40 | 45 | 63 | 30/32 × 200 | 53 | 225 | 225 | 270 | 228 |
| 2010.4020.1. | 400 × 200 | 250 × 200 | 400 × 50 | 400 × 125 | 50 | 50 | 45 | 63 | 30/32 × 200 | 53 | 310 | 110 | 155 | 313 |
| 2010.4020.2. | 400 × 200 | 250 × 200 | 400 × 50 | 400 × 125 | 50 | 40 | 45 | 63 | 30/32 × 200 | 53 | 310 | 110 | 155 | 313 |
| 2010.4020.3. | 400 × 200 | 250 × 200 | 400 × 50 | 400 × 125 | 40 | 50 | 45 | 63 | 30/32 × 200 | 53 | 310 | 110 | 155 | 313 |
| 2010.4020.4. | 400 × 200 | 250 × 200 | 400 × 50 | 400 × 125 | 40 | 40 | 45 | 63 | 30/32 × 200 | 53 | 310 | 110 | 155 | 313 |
| 2010.4025.1. | 400 × 250 | 250 × 250 | 400 × 100 | 400 × 175 | 50 | 50 | 45 | 63 | 30/32 × 200 | 53 | 310 | 160 | 205 | 313 |
| 2010.4025.2. | 400 × 250 | 250 × 250 | 400 × 100 | 400 × 175 | 50 | 40 | 45 | 63 | 30/32 × 200 | 53 | 310 | 160 | 205 | 313 |
| 2010.4025.3. | 400 × 250 | 250 × 250 | 400 × 100 | 400 × 175 | 40 | 50 | 45 | 63 | 30/32 × 200 | 53 | 310 | 160 | 205 | 313 |
| 2010.4025.4. | 400 × 250 | 250 × 250 | 400 × 100 | 400 × 175 | 40 | 40 | 45 | 63 | 30/32 × 200 | 53 | 310 | 160 | 205 | 313 |
| 2010.4031.1. | 400 × 315 | 250 × 315 | 400 × 165 | 400 × 240 | 50 | 50 | 45 | 63 | 30/32 × 200 | 53 | 310 | 225 | 270 | 313 |
| 2010.4031.2. | 400 × 315 | 250 × 315 | 400 × 165 | 400 × 240 | 50 | 40 | 45 | 63 | 30/32 × 200 | 53 | 310 | 225 | 270 | 313 |

Die set without stripper ~DIN 9868/ISO 11415

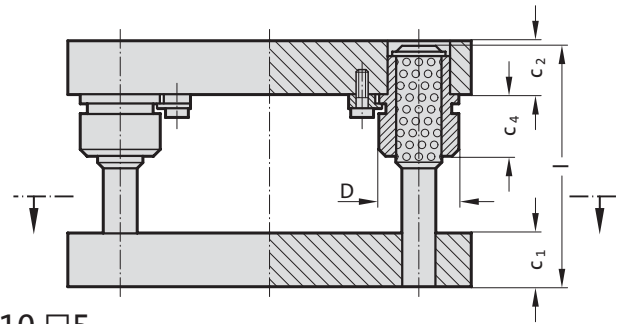

2010.□5.

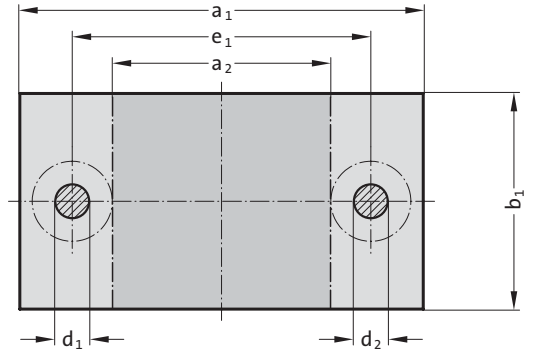

2010.□6.

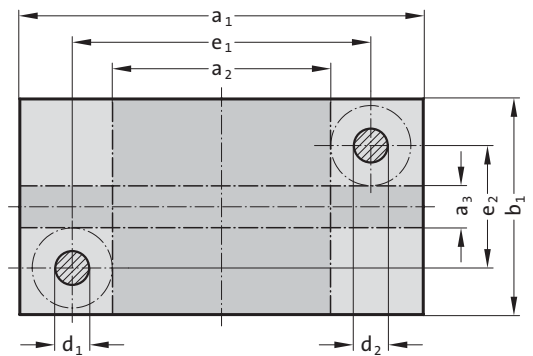

2010.□7.

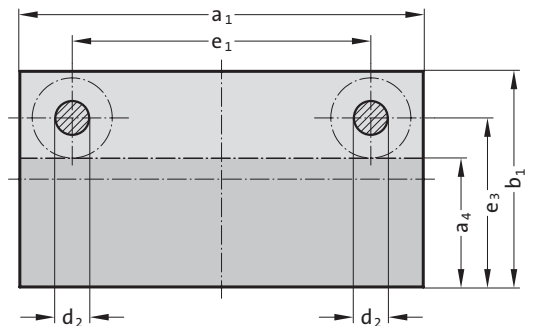

2010.□9.

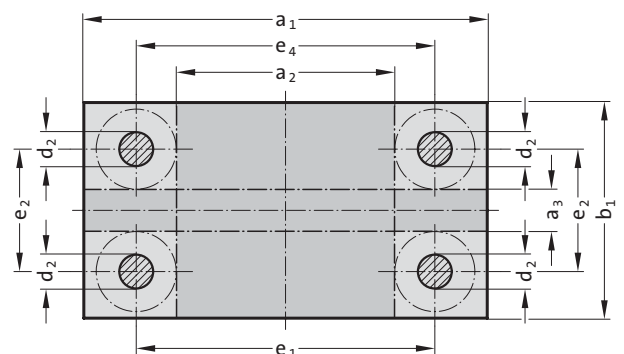

Standard Guide Systems

Headed Sintered Ferrite Bushes, carbonitrided = .834.

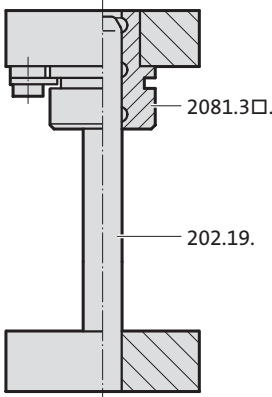

Headed Ball Bearing Bushes = .862.

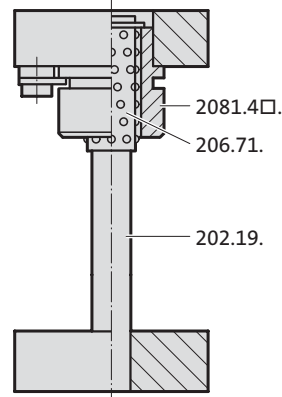

Description:

FIBRO Die Sets offer the choice between sintered ferrite sliding guides and those of the ball bearing type to DIN-ISO. Both come with headed guide bushes. These are seated in push-fit bolster bores and retained there by screw clamps.

Execution:

Steel: External contours milled, thickness surfaces ground
 a_1 or $b_1 \leq 630 = +0,2/+0,4$
 a_1 or $b_1 > 630 = +0,2/+0,6$

Aluminium: External contours sawed, thickness surfaces ground
 a_1 or $b_1 = +1/+4$

Advisory: Ordering Code:

Hole pattern for the screw clamps depends on positioning of working surface, determined by last part of the Order No,

for example: 2010.49.2520.4.862.1 lengthwise
 .2 across

Note:

On request, Standard Die Sets can also be fitted with any other FIBRO Guide Elements (see die sets to customers' drawings). FIBRO will furthermore supply die sets with special machining features.



Die set without stripper ~DIN 9868/ISO 11415

2010. □□ .

Ordering Code (principle):

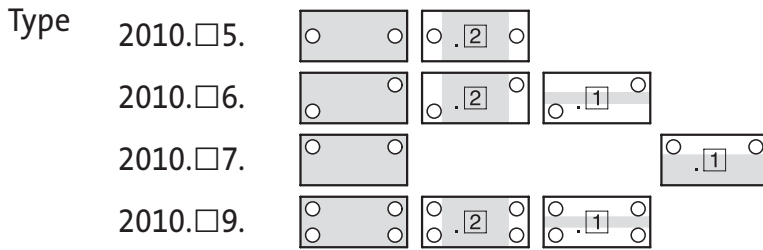

2010 . 4 5 . 4025 . 1 . 862 . 2

- Position of work area: 2
- Guide system: Headed ball bearing bushes
- Thickness combinations P: $c_1 - c_2$
- External dimensions: $a_1 = 400 \times b_1 = 290$
- Type: Position of guide elements
- Material: 4 = Steel, 6 = Aluminium
- Standard Die sets

| Order No. | external dimensions $a_1 \times b_1$ | work area across $a_2 \times b_1$ | work area lengthwise $a_1 \times a_3$ | work area lengthwise $a_1 \times a_4$ | c_{1+2} | c_{2+2} | $c_4 S$ | $c_4 K$ | $d_1/d_2 \times l$ | D | e_1 | e_2 | e_3 | e_4 | |
|-----------|--------------------------------------|-----------------------------------|---------------------------------------|---------------------------------------|-----------|-----------|---------|---------|--------------------|-------------|-------|-------|-------|-------|-----|
| 2010. | .4031. 3. | 400 × 315 | 250 × 315 | 400 × 165 | 400 × 240 | 40 | 50 | 45 | 63 | 30/32 × 200 | 53 | 310 | 225 | 270 | 313 |
| 2010. | .4031. 4. | 400 × 315 | 250 × 315 | 400 × 165 | 400 × 240 | 40 | 40 | 45 | 63 | 30/32 × 200 | 53 | 310 | 225 | 270 | 313 |
| 2010. | .4040. 1. | 400 × 400 | 250 × 400 | 400 × 250 | 400 × 325 | 50 | 50 | 45 | 63 | 30/32 × 200 | 53 | 310 | 310 | 355 | 313 |
| 2010. | .4040. 2. | 400 × 400 | 250 × 400 | 400 × 250 | 400 × 325 | 50 | 40 | 45 | 63 | 30/32 × 200 | 53 | 310 | 310 | 355 | 313 |
| 2010. | .4040. 3. | 400 × 400 | 250 × 400 | 400 × 250 | 400 × 325 | 40 | 50 | 45 | 63 | 30/32 × 200 | 53 | 310 | 310 | 355 | 313 |
| 2010. | .4040. 4. | 400 × 400 | 250 × 400 | 400 × 250 | 400 × 325 | 40 | 40 | 45 | 63 | 30/32 × 200 | 53 | 310 | 310 | 355 | 313 |
| 2010. | .5025. 1. | 500 × 250 | 330 × 250 | 500 × 80 | 500 × 165 | 50 | 50 | 45 | 71 | 38/40 × 200 | 63 | 400 | 150 | 200 | 403 |
| 2010. | .5025. 2. | 500 × 250 | 330 × 250 | 500 × 80 | 500 × 165 | 50 | 40 | 45 | 71 | 38/40 × 200 | 63 | 400 | 150 | 200 | 403 |
| 2010. | .5025. 3. | 500 × 250 | 330 × 250 | 500 × 80 | 500 × 165 | 40 | 50 | 45 | 71 | 38/40 × 200 | 63 | 400 | 150 | 200 | 403 |
| 2010. | .5025. 4. | 500 × 250 | 330 × 250 | 500 × 80 | 500 × 165 | 40 | 40 | 45 | 71 | 38/40 × 200 | 63 | 400 | 150 | 200 | 403 |
| 2010. | .5031. 1. | 500 × 315 | 330 × 315 | 500 × 145 | 500 × 230 | 50 | 50 | 45 | 71 | 38/40 × 200 | 63 | 400 | 215 | 265 | 403 |
| 2010. | .5031. 2. | 500 × 315 | 330 × 315 | 500 × 145 | 500 × 230 | 50 | 40 | 45 | 71 | 38/40 × 200 | 63 | 400 | 215 | 265 | 403 |
| 2010. | .5031. 3. | 500 × 315 | 330 × 315 | 500 × 145 | 500 × 230 | 40 | 50 | 45 | 71 | 38/40 × 200 | 63 | 400 | 215 | 265 | 403 |
| 2010. | .5031. 4. | 500 × 315 | 330 × 315 | 500 × 145 | 500 × 230 | 40 | 40 | 45 | 71 | 38/40 × 200 | 63 | 400 | 215 | 265 | 403 |
| 2010. | .5040. 1. | 500 × 400 | 330 × 400 | 500 × 230 | 500 × 315 | 50 | 50 | 45 | 71 | 38/40 × 200 | 63 | 400 | 300 | 350 | 403 |
| 2010. | .5040. 2. | 500 × 400 | 330 × 400 | 500 × 230 | 500 × 315 | 50 | 40 | 45 | 71 | 38/40 × 200 | 63 | 400 | 300 | 350 | 403 |
| 2010. | .5040. 3. | 500 × 400 | 330 × 400 | 500 × 230 | 500 × 315 | 40 | 50 | 45 | 71 | 38/40 × 200 | 63 | 400 | 300 | 350 | 403 |
| 2010. | .5040. 4. | 500 × 400 | 330 × 400 | 500 × 230 | 500 × 315 | 40 | 40 | 45 | 71 | 38/40 × 200 | 63 | 400 | 300 | 350 | 403 |
| 2010. | .5050. 1. | 500 × 500 | 330 × 500 | 500 × 330 | 500 × 415 | 50 | 50 | 45 | 71 | 38/40 × 200 | 63 | 400 | 400 | 450 | 403 |
| 2010. | .5050. 2. | 500 × 500 | 330 × 500 | 500 × 330 | 500 × 415 | 50 | 40 | 45 | 71 | 38/40 × 200 | 63 | 400 | 400 | 450 | 403 |
| 2010. | .5050. 3. | 500 × 500 | 330 × 500 | 500 × 330 | 500 × 415 | 40 | 50 | 45 | 71 | 38/40 × 200 | 63 | 400 | 400 | 450 | 403 |
| 2010. | .5050. 4. | 500 × 500 | 330 × 500 | 500 × 330 | 500 × 415 | 40 | 40 | 45 | 71 | 38/40 × 200 | 63 | 400 | 400 | 450 | 403 |
| 2010. | .6331. 1. | 630 × 315 | 430 × 315 | 630 × 115 | 630 × 215 | 63 | 63 | 50 | 80 | 48/50 × 250 | 77 | 510 | 195 | 255 | 513 |
| 2010. | .6331. 2. | 630 × 315 | 430 × 315 | 630 × 115 | 630 × 215 | 63 | 50 | 50 | 80 | 48/50 × 250 | 77 | 510 | 195 | 255 | 513 |
| 2010. | .6331. 3. | 630 × 315 | 430 × 315 | 630 × 115 | 630 × 215 | 50 | 63 | 50 | 80 | 48/50 × 224 | 77 | 510 | 195 | 255 | 513 |
| 2010. | .6331. 4. | 630 × 315 | 430 × 315 | 630 × 115 | 630 × 215 | 50 | 50 | 50 | 80 | 48/50 × 224 | 77 | 510 | 195 | 255 | 513 |
| 2010. | .6340. 1. | 630 × 400 | 430 × 400 | 630 × 200 | 630 × 300 | 63 | 63 | 50 | 80 | 48/50 × 250 | 77 | 510 | 280 | 340 | 513 |
| 2010. | .6340. 2. | 630 × 400 | 430 × 400 | 630 × 200 | 630 × 300 | 63 | 50 | 50 | 80 | 48/50 × 250 | 77 | 510 | 280 | 340 | 513 |
| 2010. | .6340. 3. | 630 × 400 | 430 × 400 | 630 × 200 | 630 × 300 | 50 | 63 | 50 | 80 | 48/50 × 224 | 77 | 510 | 280 | 340 | 513 |
| 2010. | .6340. 4. | 630 × 400 | 430 × 400 | 630 × 200 | 630 × 300 | 50 | 50 | 50 | 80 | 48/50 × 224 | 77 | 510 | 280 | 340 | 513 |
| 2010. | .6350. 1. | 630 × 500 | 430 × 500 | 630 × 300 | 630 × 400 | 63 | 63 | 50 | 80 | 48/50 × 250 | 77 | 510 | 380 | 440 | 513 |
| 2010. | .6350. 2. | 630 × 500 | 430 × 500 | 630 × 300 | 630 × 400 | 63 | 50 | 50 | 80 | 48/50 × 250 | 77 | 510 | 380 | 440 | 513 |
| 2010. | .6350. 3. | 630 × 500 | 430 × 500 | 630 × 300 | 630 × 400 | 50 | 63 | 50 | 80 | 48/50 × 224 | 77 | 510 | 380 | 440 | 513 |
| 2010. | .6350. 4. | 630 × 500 | 430 × 500 | 630 × 300 | 630 × 400 | 50 | 50 | 50 | 80 | 48/50 × 224 | 77 | 510 | 380 | 440 | 513 |
| 2010. | .6363. 1. | 630 × 630 | 430 × 630 | 630 × 430 | 630 × 530 | 63 | 63 | 50 | 80 | 48/50 × 250 | 77 | 510 | 510 | 570 | 513 |
| 2010. | .6363. 2. | 630 × 630 | 430 × 630 | 630 × 430 | 630 × 530 | 63 | 50 | 50 | 80 | 48/50 × 250 | 77 | 510 | 510 | 570 | 513 |
| 2010. | .6363. 3. | 630 × 630 | 430 × 630 | 630 × 430 | 630 × 530 | 50 | 63 | 50 | 80 | 48/50 × 224 | 77 | 510 | 510 | 570 | 513 |
| 2010. | .6363. 4. | 630 × 630 | 430 × 630 | 630 × 430 | 630 × 530 | 50 | 50 | 50 | 80 | 48/50 × 224 | 77 | 510 | 510 | 570 | 513 |
| 2010. | .7140. 1. | 710 × 400 | 510 × 400 | 710 × 200 | 710 × 300 | 63 | 63 | 50 | 80 | 48/50 × 250 | 77 | 590 | 280 | 340 | 593 |
| 2010. | .7140. 2. | 710 × 400 | 510 × 400 | 710 × 200 | 710 × 300 | 63 | 50 | 50 | 80 | 48/50 × 250 | 77 | 590 | 280 | 340 | 593 |
| 2010. | .7140. 3. | 710 × 400 | 510 × 400 | 710 × 200 | 710 × 300 | 50 | 63 | 50 | 80 | 48/50 × 224 | 77 | 590 | 280 | 340 | 593 |
| 2010. | .7140. 4. | 710 × 400 | 510 × 400 | 710 × 200 | 710 × 300 | 50 | 50 | 50 | 80 | 48/50 × 224 | 77 | 590 | 280 | 340 | 593 |
| 2010. | .7150. 1. | 710 × 500 | 510 × 500 | 710 × 300 | 710 × 400 | 63 | 63 | 50 | 80 | 48/50 × 250 | 77 | 590 | 380 | 440 | 593 |
| 2010. | .7150. 2. | 710 × 500 | 510 × 500 | 710 × 300 | 710 × 400 | 63 | 50 | 50 | 80 | 48/50 × 250 | 77 | 590 | 380 | 440 | 593 |
| 2010. | .7150. 3. | 710 × 500 | 510 × 500 | 710 × 300 | 710 × 400 | 50 | 63 | 50 | 80 | 48/50 × 224 | 77 | 590 | 380 | 440 | 593 |
| 2010. | .7150. 4. | 710 × 500 | 510 × 500 | 710 × 300 | 710 × 400 | 50 | 50 | 50 | 80 | 48/50 × 224 | 77 | 590 | 380 | 440 | 593 |
| 2010. | .7163. 1. | 710 × 630 | 510 × 630 | 710 × 430 | 710 × 530 | 63 | 63 | 50 | 80 | 48/50 × 250 | 77 | 590 | 510 | 570 | 593 |
| 2010. | .7163. 2. | 710 × 630 | 510 × 630 | 710 × 430 | 710 × 530 | 63 | 50 | 50 | 80 | 48/50 × 250 | 77 | 590 | 510 | 570 | 593 |
| 2010. | .7163. 3. | 710 × 630 | 510 × 630 | 710 × 430 | 710 × 530 | 50 | 63 | 50 | 80 | 48/50 × 224 | 77 | 590 | 510 | 570 | 593 |
| 2010. | .7163. 4. | 710 × 630 | 510 × 630 | 710 × 430 | 710 × 530 | 50 | 50 | 50 | 80 | 48/50 × 224 | 77 | 590 | 510 | 570 | 593 |
| 2010. | .8040. 1. | 800 × 400 | 600 × 400 | 800 × 200 | 800 × 300 | 63 | 63 | 50 | 80 | 48/50 × 250 | 77 | 680 | 280 | 340 | 683 |
| 2010. | .8040. 2. | 800 × 400 | 600 × 400 | 800 × 200 | 800 × 300 | 63 | 50 | 50 | 80 | 48/50 × 250 | 77 | 680 | 280 | 340 | 683 |
| 2010. | .8040. 3. | 800 × 400 | 600 × 400 | 800 × 200 | 800 × 300 | 50 | 63 | 50 | 80 | 48/50 × 224 | 77 | 680 | 280 | 340 | 683 |
| 2010. | .8040. 4. | 800 × 400 | 600 × 400 | 800 × 200 | 800 × 300 | 50 | 50 | 50 | 80 | 48/50 × 224 | 77 | 680 | 280 | 340 | 683 |
| 2010. | .8050. 1. | 800 × 500 | 600 × 500 | 800 × 300 | 800 × 400 | 63 | 63 | 50 | 80 | 48/50 × 250 | 77 | 680 | 380 | 440 | 683 |
| 2010. | .8050. 2. | 800 × 500 | 600 × 500 | 800 × 300 | 800 × 400 | 63 | 50 | 50 | 80 | 48/50 × 250 | 77 | 680 | 380 | 440 | 683 |
| 2010. | .8050. 3. | 800 × 500 | 600 × 500 | 800 × 300 | 800 × 400 | 50 | 63 | 50 | 80 | 48/50 × 224 | 77 | 680 | 380 | 440 | 683 |
| 2010. | .8050. 4. | 800 × 500 | 600 × 500 | 800 × 300 | 800 × 400 | 50 | 50 | 50 | 80 | 48/50 × 224 | 77 | 680 | 380 | 440 | 683 |
| 2010. | .8063. 1. | 800 × 630 | 600 × 630 | 800 × 430 | 800 × 530 | 63 | 63 | 50 | 80 | 48/50 × 250 | 77 | 680 | 510 | 570 | 683 |
| 2010. | .8063. 2. | 800 × 630 | 600 × 630 | 800 × 430 | 800 × 530 | 63 | 50 | 50 | 80 | 48/50 × 250 | 77 | 680 | 510 | 570 | 683 |
| 2010. | .8063. 3. | 800 × 630 | 600 × 630 | 800 × 430 | 800 × 530 | 50 | 63 | 50 | 80 | 48/50 × 224 | 77 | 680 | 510 | 570 | 683 |
| 2010. | .8063. 4. | 800 × 630 | 600 × 630 | 800 × 430 | 800 × 530 | 50 | 50 | 50 | 80 | 48/50 × 224 | 77 | 680 | 510 | 570 | 683 |

Die set with stripper ~DIN 9868/ISO 11415

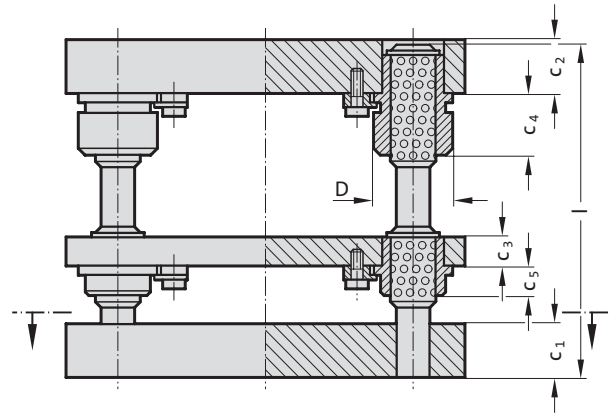

2010.□5.

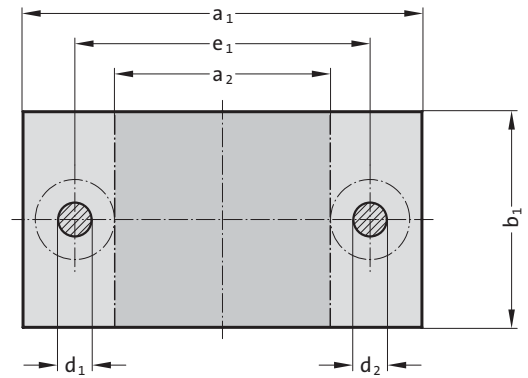

2010.□6.

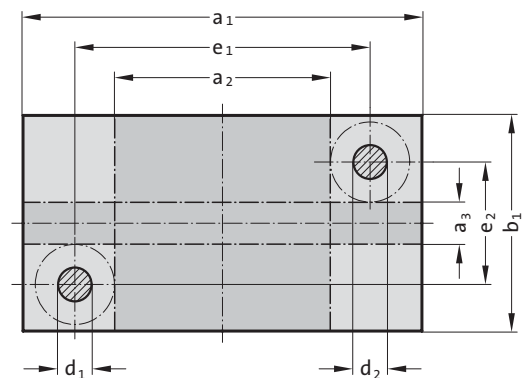

2010.□9.

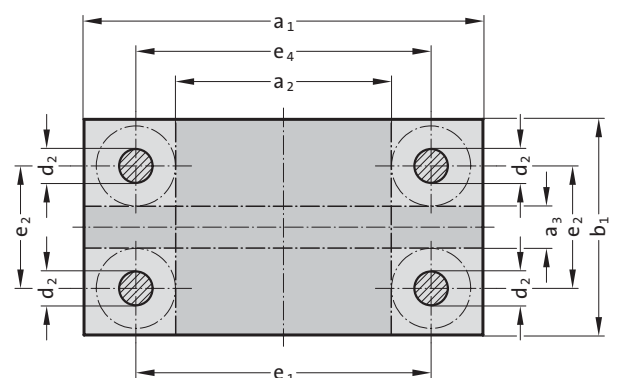

Standard Guide Systems

Headed Sintered Ferrite Bushes, carbonitrided = .835.

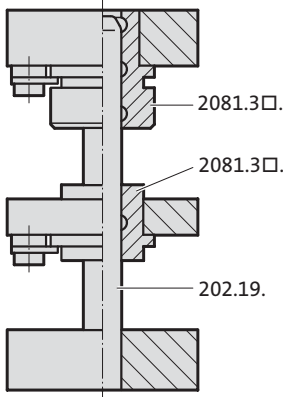

Headed Ball Bearing Bushes = .865.

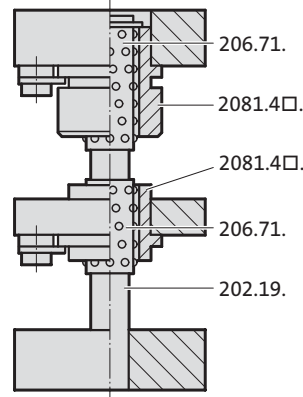

Description:

FIBRO Die Sets offer the choice between sintered ferrite sliding guides and those of the ball bearing type to DIN-ISO. Both come with headed guide bushes. These are seated in push-fit bolster bores and retained there by screw clamps.



Execution:

Steel: External contours milled, thickness surfaces ground
 a_1 or $b_1 \leq 630 = +0,2/+0,4$
 a_1 or $b_1 > 630 = +0,2/+0,6$

Aluminium: External contours sawed, thickness surfaces ground
 a_1 or $b_1 = +1/+4$

Advisory: Ordering Code:

Hole pattern for the screw clamps depends on positioning of working surface, determined by last part of the Order No,

for example: 2010.49.2520.4.865.1  lengthwise
 .2  across

Note:

On request, Standard Die Sets can also be fitted with any other FIBRO Guide Elements (see die sets to customers' drawings). FIBRO will furthermore supply die sets with special machining features.



Die set with stripper ~DIN 9868/ISO 11415

2010. □□ .

Ordering Code (principle):

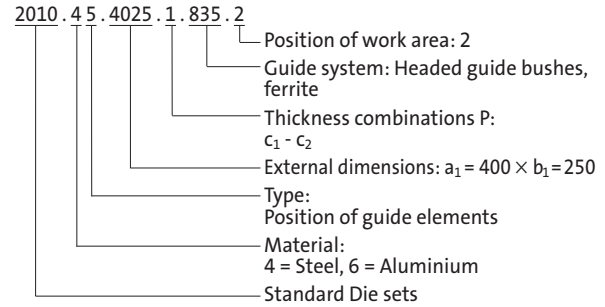
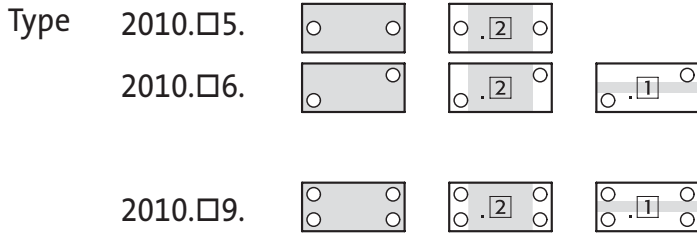

| Order No. | external dimensions $a_1 \times b_1$ | work area across $a_2 \times b_1$ | work area lengthwise $a_1 \times a_3$ | C_{1+2} | C_{2+2} | C_{3+2} | C_4 | C_5 | $d_1/d_2 \times l$ | D | e_1 | e_2 | e_4 | |
|-----------|---|--------------------------------------|--|-----------|-----------|-----------|-------|-------|--------------------|-------------|-------|-------|-------|-----|
| 2010. | .1608. 1. | 160 × 80 | 60 × 80 | — | 32 | 32 | 25 | 12 | 12 | 19/20 × 180 | 39 | 100 | — | — |
| 2010. | .1610. 1. | 160 × 100 | 60 × 100 | — | 32 | 32 | 25 | 12 | 12 | 19/20 × 180 | 39 | 100 | — | — |
| 2010. | .1612. 1. | 160 × 125 | 60 × 125 | — | 32 | 32 | 25 | 12 | 12 | 19/20 × 180 | 39 | 100 | — | — |
| 2010. | .1616. 1. | 160 × 160 | 60 × 160 | 160 × 60 | 32 | 32 | 25 | 12 | 12 | 19/20 × 180 | 39 | 100 | 100 | 103 |
| 2010. | .2010. 1. | 200 × 100 | 70 × 100 | — | 40 | 40 | 25 | 25 | 12 | 24/25 × 200 | 46 | 120 | — | — |
| 2010. | .2010. 2. | 200 × 100 | 70 × 100 | — | 40 | 32 | 25 | 25 | 12 | 24/25 × 200 | 46 | 120 | — | — |
| 2010. | .2010. 3. | 200 × 100 | 70 × 100 | — | 32 | 40 | 25 | 25 | 12 | 24/25 × 200 | 46 | 120 | — | — |
| 2010. | .2010. 4. | 200 × 100 | 70 × 100 | — | 32 | 32 | 25 | 25 | 12 | 24/25 × 200 | 46 | 120 | — | — |
| 2010. | .2012. 1. | 200 × 125 | 70 × 125 | — | 40 | 40 | 25 | 25 | 12 | 24/25 × 200 | 46 | 120 | — | — |
| 2010. | .2012. 2. | 200 × 125 | 70 × 125 | — | 40 | 32 | 25 | 25 | 12 | 24/25 × 200 | 46 | 120 | — | — |
| 2010. | .2012. 3. | 200 × 125 | 70 × 125 | — | 32 | 40 | 25 | 25 | 12 | 24/25 × 200 | 46 | 120 | — | — |
| 2010. | .2012. 4. | 200 × 125 | 70 × 125 | — | 32 | 32 | 25 | 25 | 12 | 24/25 × 200 | 46 | 120 | — | — |
| 2010. | .2016. 1. | 200 × 160 | 70 × 160 | — | 40 | 40 | 25 | 25 | 12 | 24/25 × 200 | 46 | 120 | — | — |
| 2010. | .2016. 2. | 200 × 160 | 70 × 160 | — | 40 | 32 | 25 | 25 | 12 | 24/25 × 200 | 46 | 120 | — | — |
| 2010. | .2016. 3. | 200 × 160 | 70 × 160 | — | 32 | 40 | 25 | 25 | 12 | 24/25 × 200 | 46 | 120 | — | — |
| 2010. | .2016. 4. | 200 × 160 | 70 × 160 | — | 32 | 32 | 25 | 25 | 12 | 24/25 × 200 | 46 | 120 | — | — |
| 2010. | .2020. 1. | 200 × 200 | 70 × 200 | 200 × 70 | 40 | 40 | 25 | 25 | 12 | 24/25 × 200 | 46 | 120 | 120 | 123 |
| 2010. | .2020. 2. | 200 × 200 | 70 × 200 | 200 × 70 | 40 | 32 | 25 | 25 | 12 | 24/25 × 200 | 46 | 120 | 120 | 123 |
| 2010. | .2020. 3. | 200 × 200 | 70 × 200 | 200 × 70 | 32 | 40 | 25 | 25 | 12 | 24/25 × 200 | 46 | 120 | 120 | 123 |
| 2010. | .2020. 4. | 200 × 200 | 70 × 200 | 200 × 70 | 32 | 32 | 25 | 25 | 12 | 24/25 × 200 | 46 | 120 | 120 | 123 |
| 2010. | .2512. 1. | 250 × 125 | 120 × 125 | — | 40 | 40 | 25 | 25 | 12 | 24/25 × 200 | 46 | 170 | — | — |
| 2010. | .2512. 2. | 250 × 125 | 120 × 125 | — | 40 | 32 | 25 | 25 | 12 | 24/25 × 200 | 46 | 170 | — | — |
| 2010. | .2512. 3. | 250 × 125 | 120 × 125 | — | 32 | 40 | 25 | 25 | 12 | 24/25 × 200 | 46 | 170 | — | — |
| 2010. | .2512. 4. | 250 × 125 | 120 × 125 | — | 32 | 32 | 25 | 25 | 12 | 24/25 × 200 | 46 | 170 | — | — |
| 2010. | .2516. 1. | 250 × 160 | 120 × 160 | — | 40 | 40 | 25 | 25 | 12 | 24/25 × 200 | 46 | 170 | — | — |
| 2010. | .2516. 2. | 250 × 160 | 120 × 160 | — | 40 | 32 | 25 | 25 | 12 | 24/25 × 200 | 46 | 170 | — | — |
| 2010. | .2516. 3. | 250 × 160 | 120 × 160 | — | 32 | 40 | 25 | 25 | 12 | 24/25 × 200 | 46 | 170 | — | — |
| 2010. | .2516. 4. | 250 × 160 | 120 × 160 | — | 32 | 32 | 25 | 25 | 12 | 24/25 × 200 | 46 | 170 | — | — |
| 2010. | .2520. 1. | 250 × 200 | 120 × 200 | 250 × 70 | 40 | 40 | 25 | 25 | 12 | 24/25 × 200 | 46 | 170 | 120 | 173 |
| 2010. | .2520. 2. | 250 × 200 | 120 × 200 | 250 × 70 | 40 | 32 | 25 | 25 | 12 | 24/25 × 200 | 46 | 170 | 120 | 173 |
| 2010. | .2520. 3. | 250 × 200 | 120 × 200 | 250 × 70 | 32 | 40 | 25 | 25 | 12 | 24/25 × 200 | 46 | 170 | 120 | 173 |
| 2010. | .2520. 4. | 250 × 200 | 120 × 200 | 250 × 70 | 32 | 32 | 25 | 25 | 12 | 24/25 × 200 | 46 | 170 | 120 | 173 |
| 2010. | .2525. 1. | 250 × 250 | 120 × 250 | 250 × 120 | 40 | 40 | 25 | 25 | 12 | 24/25 × 200 | 46 | 170 | 170 | 173 |
| 2010. | .2525. 2. | 250 × 250 | 120 × 250 | 250 × 120 | 40 | 32 | 25 | 25 | 12 | 24/25 × 200 | 46 | 170 | 170 | 173 |
| 2010. | .2525. 3. | 250 × 250 | 120 × 250 | 250 × 120 | 32 | 40 | 25 | 25 | 12 | 24/25 × 200 | 46 | 170 | 170 | 173 |
| 2010. | .2525. 4. | 250 × 250 | 120 × 250 | 250 × 120 | 32 | 32 | 25 | 25 | 12 | 24/25 × 200 | 46 | 170 | 170 | 173 |
| 2010. | .3116. 1. | 315 × 160 | 165 × 160 | — | 50 | 50 | 32 | 32 | 12 | 30/32 × 224 | 53 | 225 | — | — |
| 2010. | .3116. 2. | 315 × 160 | 165 × 160 | — | 50 | 40 | 32 | 32 | 12 | 30/32 × 224 | 53 | 225 | — | — |
| 2010. | .3116. 3. | 315 × 160 | 165 × 160 | — | 40 | 50 | 32 | 32 | 12 | 30/32 × 224 | 53 | 225 | — | — |
| 2010. | .3116. 4. | 315 × 160 | 165 × 160 | — | 40 | 40 | 32 | 32 | 12 | 30/32 × 224 | 53 | 225 | — | — |
| 2010. | .3120. 1. | 315 × 200 | 165 × 200 | 315 × 50 | 50 | 50 | 32 | 32 | 12 | 30/32 × 224 | 53 | 225 | 110 | 228 |
| 2010. | .3120. 2. | 315 × 200 | 165 × 200 | 315 × 50 | 50 | 40 | 32 | 32 | 12 | 30/32 × 224 | 53 | 225 | 110 | 228 |
| 2010. | .3120. 3. | 315 × 200 | 165 × 200 | 315 × 50 | 40 | 50 | 32 | 32 | 12 | 30/32 × 224 | 53 | 225 | 110 | 228 |
| 2010. | .3120. 4. | 315 × 200 | 165 × 200 | 315 × 50 | 40 | 40 | 32 | 32 | 12 | 30/32 × 224 | 53 | 225 | 110 | 228 |
| 2010. | .3125. 1. | 315 × 250 | 165 × 250 | 315 × 100 | 50 | 50 | 32 | 32 | 12 | 30/32 × 224 | 53 | 225 | 160 | 228 |
| 2010. | .3125. 2. | 315 × 250 | 165 × 250 | 315 × 100 | 50 | 40 | 32 | 32 | 12 | 30/32 × 224 | 53 | 225 | 160 | 228 |
| 2010. | .3125. 3. | 315 × 250 | 165 × 250 | 315 × 100 | 40 | 50 | 32 | 32 | 12 | 30/32 × 224 | 53 | 225 | 160 | 228 |
| 2010. | .3125. 4. | 315 × 250 | 165 × 250 | 315 × 100 | 40 | 40 | 32 | 32 | 12 | 30/32 × 224 | 53 | 225 | 160 | 228 |
| 2010. | .3131. 1. | 315 × 315 | 165 × 315 | 315 × 165 | 50 | 50 | 32 | 32 | 12 | 30/32 × 224 | 53 | 225 | 225 | 228 |
| 2010. | .3131. 2. | 315 × 315 | 165 × 315 | 315 × 165 | 50 | 40 | 32 | 32 | 12 | 30/32 × 224 | 53 | 225 | 225 | 228 |
| 2010. | .3131. 3. | 315 × 315 | 165 × 315 | 315 × 165 | 40 | 50 | 32 | 32 | 12 | 30/32 × 224 | 53 | 225 | 225 | 228 |
| 2010. | .3131. 4. | 315 × 315 | 165 × 315 | 315 × 165 | 40 | 40 | 32 | 32 | 12 | 30/32 × 224 | 53 | 225 | 225 | 228 |
| 2010. | .4020. 1. | 400 × 200 | 250 × 200 | 400 × 50 | 50 | 50 | 32 | 32 | 12 | 30/32 × 224 | 53 | 310 | 110 | 313 |
| 2010. | .4020. 2. | 400 × 200 | 250 × 200 | 400 × 50 | 50 | 40 | 32 | 32 | 12 | 30/32 × 224 | 53 | 310 | 110 | 313 |
| 2010. | .4020. 3. | 400 × 200 | 250 × 200 | 400 × 50 | 40 | 50 | 32 | 32 | 12 | 30/32 × 224 | 53 | 310 | 110 | 313 |
| 2010. | .4020. 4. | 400 × 200 | 250 × 200 | 400 × 50 | 40 | 40 | 32 | 32 | 12 | 30/32 × 224 | 53 | 310 | 110 | 313 |
| 2010. | .4025. 1. | 400 × 250 | 250 × 250 | 400 × 100 | 50 | 50 | 32 | 32 | 12 | 30/32 × 224 | 53 | 310 | 160 | 313 |
| 2010. | .4025. 2. | 400 × 250 | 250 × 250 | 400 × 100 | 50 | 40 | 32 | 32 | 12 | 30/32 × 224 | 53 | 310 | 160 | 313 |
| 2010. | .4025. 3. | 400 × 250 | 250 × 250 | 400 × 100 | 40 | 50 | 32 | 32 | 12 | 30/32 × 224 | 53 | 310 | 160 | 313 |
| 2010. | .4025. 4. | 400 × 250 | 250 × 250 | 400 × 100 | 40 | 40 | 32 | 32 | 12 | 30/32 × 224 | 53 | 310 | 160 | 313 |
| 2010. | .4031. 1. | 400 × 315 | 250 × 315 | 400 × 165 | 50 | 50 | 32 | 32 | 12 | 30/32 × 224 | 53 | 310 | 225 | 313 |
| 2010. | .4031. 2. | 400 × 315 | 250 × 315 | 400 × 165 | 50 | 40 | 32 | 32 | 12 | 30/32 × 224 | 53 | 310 | 225 | 313 |

Die set with stripper ~DIN 9868/ISO 11415

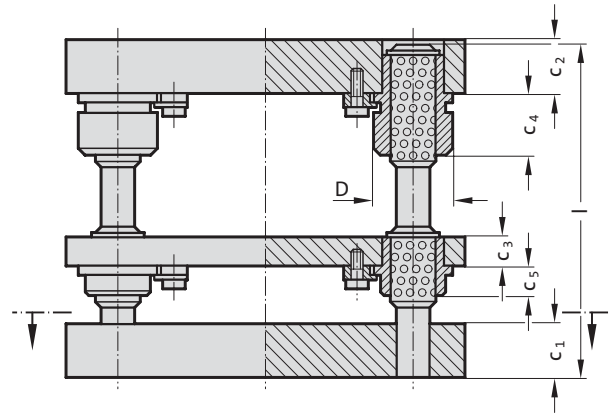

2010.□5.

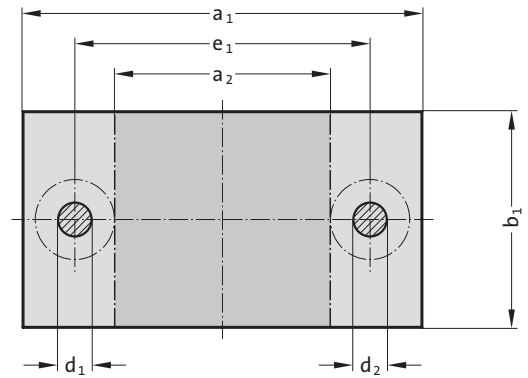

2010.□6.

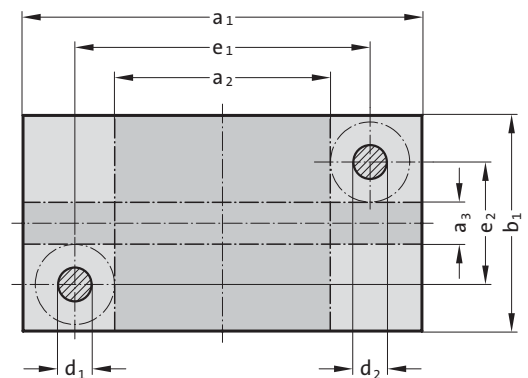

2010.□9.

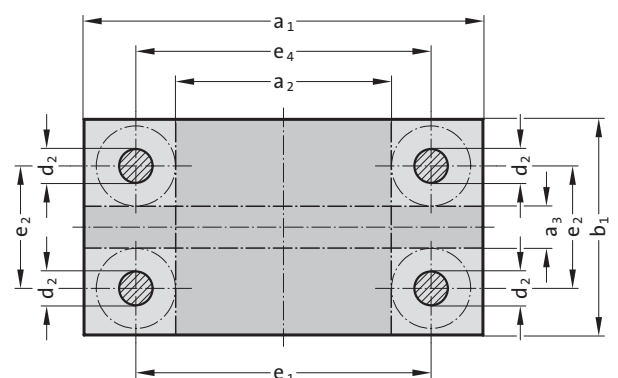

Standard Guide Systems

Headed Sintered Ferrite Bushes, carbonitrided = .835.

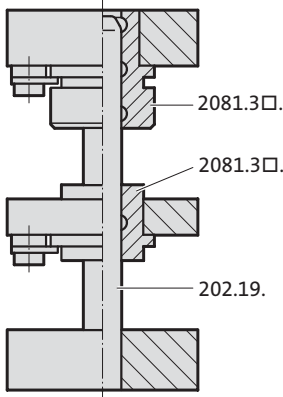

Headed Ball Bearing Bushes = .865.

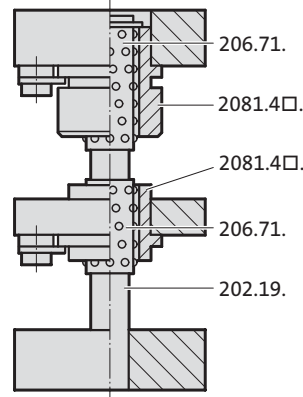

Description:

FIBRO Die Sets offer the choice between sintered ferrite sliding guides and those of the ball bearing type to DIN-ISO. Both come with headed guide bushes. These are seated in push-fit bolster bores and retained there by screw clamps.

Execution:

Steel: External contours milled, thickness surfaces ground
 a_1 or $b_1 \leq 630 = +0,2/+0,4$
 a_1 or $b_1 > 630 = +0,2/+0,6$

Aluminium: External contours sawed, thickness surfaces ground
 a_1 or $b_1 = +1/+4$

Advisory: Ordering Code:

Hole pattern for the screw clamps depends on positioning of working surface, determined by last part of the Order No,

for example: 2010.49.2520.4.865.1 lengthwise
 .2 across

Note:

On request, Standard Die Sets can also be fitted with any other FIBRO Guide Elements (see die sets to customers' drawings). FIBRO will furthermore supply die sets with special machining features.



Die set with stripper ~DIN 9868/ISO 11415

2010. □□ .

Ordering Code (principle):

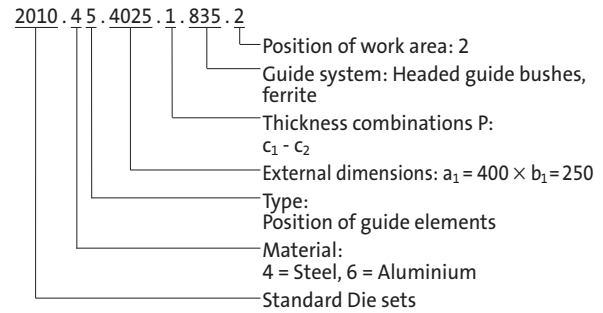
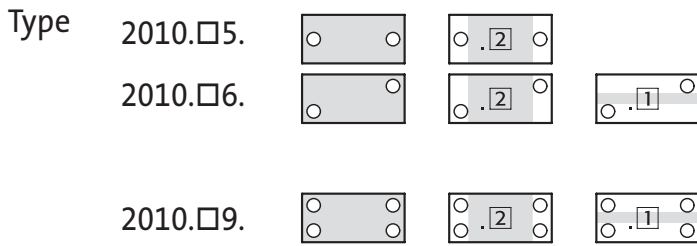

| Order No. | external dimensions $a_1 \times b_1$ | work area across $a_2 \times b_1$ | work area lengthwise $a_1 \times a_3$ | C_{1+2} | C_{2+2} | C_{3+2} | C_4 | C_5 | $d_1/d_2 \times l$ | D | e_1 | e_2 | e_4 |
|--------------|---|--------------------------------------|--|-----------|-----------|-----------|-------|-------|--------------------|----|-------|-------|-------|
| 2010.4031.3. | 400 × 315 | 250 × 315 | 400 × 165 | 40 | 50 | 32 | 32 | 12 | 30/32 × 224 | 53 | 310 | 225 | 313 |
| 2010.4031.4. | 400 × 315 | 250 × 315 | 400 × 165 | 40 | 40 | 32 | 32 | 12 | 30/32 × 224 | 53 | 310 | 225 | 313 |
| 2010.4040.1. | 400 × 400 | 250 × 400 | 400 × 250 | 50 | 50 | 32 | 32 | 12 | 30/32 × 224 | 53 | 310 | 310 | 313 |
| 2010.4040.2. | 400 × 400 | 250 × 400 | 400 × 250 | 50 | 40 | 32 | 32 | 12 | 30/32 × 224 | 53 | 310 | 310 | 313 |
| 2010.4040.3. | 400 × 400 | 250 × 400 | 400 × 250 | 40 | 50 | 32 | 32 | 12 | 30/32 × 224 | 53 | 310 | 310 | 313 |
| 2010.4040.4. | 400 × 400 | 250 × 400 | 400 × 250 | 40 | 40 | 32 | 32 | 12 | 30/32 × 224 | 53 | 310 | 310 | 313 |
| 2010.5025.1. | 500 × 250 | 330 × 250 | 500 × 80 | 50 | 50 | 32 | 32 | 15 | 38/40 × 224 | 63 | 400 | 150 | 403 |
| 2010.5025.2. | 500 × 250 | 330 × 250 | 500 × 80 | 50 | 40 | 32 | 45 | 15 | 38/40 × 224 | 63 | 400 | 150 | 403 |
| 2010.5025.3. | 500 × 250 | 330 × 250 | 500 × 80 | 40 | 50 | 32 | 32 | 15 | 38/40 × 224 | 63 | 400 | 150 | 403 |
| 2010.5025.4. | 500 × 250 | 330 × 250 | 500 × 80 | 40 | 40 | 32 | 45 | 15 | 38/40 × 224 | 63 | 400 | 150 | 403 |
| 2010.5031.1. | 500 × 315 | 330 × 315 | 500 × 145 | 50 | 50 | 32 | 32 | 15 | 38/40 × 224 | 63 | 400 | 215 | 403 |
| 2010.5031.2. | 500 × 315 | 330 × 315 | 500 × 145 | 50 | 40 | 32 | 45 | 15 | 38/40 × 224 | 63 | 400 | 215 | 403 |
| 2010.5031.3. | 500 × 315 | 330 × 315 | 500 × 145 | 40 | 50 | 32 | 32 | 15 | 38/40 × 224 | 63 | 400 | 215 | 403 |
| 2010.5031.4. | 500 × 315 | 330 × 315 | 500 × 145 | 40 | 40 | 32 | 45 | 15 | 38/40 × 224 | 63 | 400 | 215 | 403 |
| 2010.5040.1. | 500 × 400 | 330 × 400 | 500 × 230 | 50 | 50 | 32 | 32 | 15 | 38/40 × 224 | 63 | 400 | 300 | 403 |
| 2010.5040.2. | 500 × 400 | 330 × 400 | 500 × 230 | 50 | 40 | 32 | 45 | 15 | 38/40 × 224 | 63 | 400 | 300 | 403 |
| 2010.5040.3. | 500 × 400 | 330 × 400 | 500 × 230 | 40 | 50 | 32 | 32 | 15 | 38/40 × 224 | 63 | 400 | 300 | 403 |
| 2010.5040.4. | 500 × 400 | 330 × 400 | 500 × 230 | 40 | 40 | 32 | 45 | 15 | 38/40 × 224 | 63 | 400 | 300 | 403 |
| 2010.5050.1. | 500 × 500 | 330 × 500 | 500 × 330 | 50 | 50 | 32 | 32 | 15 | 38/40 × 224 | 63 | 400 | 400 | 403 |
| 2010.5050.2. | 500 × 500 | 330 × 500 | 500 × 330 | 50 | 40 | 32 | 45 | 15 | 38/40 × 224 | 63 | 400 | 400 | 403 |
| 2010.5050.3. | 500 × 500 | 330 × 500 | 500 × 330 | 40 | 50 | 32 | 32 | 15 | 38/40 × 224 | 63 | 400 | 400 | 403 |
| 2010.5050.4. | 500 × 500 | 330 × 500 | 500 × 330 | 40 | 40 | 32 | 45 | 15 | 38/40 × 224 | 63 | 400 | 400 | 403 |
| 2010.6331.1. | 630 × 315 | 430 × 315 | 630 × 115 | 63 | 63 | 40 | 36 | 18 | 48/50 × 280 | 77 | 510 | 195 | 513 |
| 2010.6331.2. | 630 × 315 | 430 × 315 | 630 × 115 | 63 | 50 | 40 | 50 | 18 | 48/50 × 280 | 77 | 510 | 195 | 513 |
| 2010.6331.3. | 630 × 315 | 430 × 315 | 630 × 115 | 50 | 63 | 40 | 36 | 18 | 48/50 × 250 | 77 | 510 | 195 | 513 |
| 2010.6331.4. | 630 × 315 | 430 × 315 | 630 × 115 | 50 | 50 | 40 | 50 | 18 | 48/50 × 250 | 77 | 510 | 195 | 513 |
| 2010.6340.1. | 630 × 400 | 430 × 400 | 630 × 200 | 63 | 63 | 40 | 36 | 18 | 48/50 × 280 | 77 | 510 | 280 | 513 |
| 2010.6340.2. | 630 × 400 | 430 × 400 | 630 × 200 | 63 | 50 | 40 | 50 | 18 | 48/50 × 280 | 77 | 510 | 280 | 513 |
| 2010.6340.3. | 630 × 400 | 430 × 400 | 630 × 200 | 50 | 63 | 40 | 36 | 18 | 48/50 × 250 | 77 | 510 | 280 | 513 |
| 2010.6340.4. | 630 × 400 | 430 × 400 | 630 × 200 | 50 | 50 | 40 | 50 | 18 | 48/50 × 250 | 77 | 510 | 280 | 513 |
| 2010.6350.1. | 630 × 500 | 430 × 500 | 630 × 300 | 63 | 63 | 40 | 36 | 18 | 48/50 × 280 | 77 | 510 | 380 | 513 |
| 2010.6350.2. | 630 × 500 | 430 × 500 | 630 × 300 | 63 | 50 | 40 | 50 | 18 | 48/50 × 280 | 77 | 510 | 380 | 513 |
| 2010.6350.3. | 630 × 500 | 430 × 500 | 630 × 300 | 50 | 63 | 40 | 36 | 18 | 48/50 × 250 | 77 | 510 | 380 | 513 |
| 2010.6350.4. | 630 × 500 | 430 × 500 | 630 × 300 | 50 | 50 | 40 | 50 | 18 | 48/50 × 250 | 77 | 510 | 380 | 513 |
| 2010.6363.1. | 630 × 630 | 430 × 630 | 630 × 430 | 63 | 63 | 40 | 36 | 18 | 48/50 × 280 | 77 | 510 | 510 | 513 |
| 2010.6363.2. | 630 × 630 | 430 × 630 | 630 × 430 | 63 | 50 | 40 | 50 | 18 | 48/50 × 280 | 77 | 510 | 510 | 513 |
| 2010.6363.3. | 630 × 630 | 430 × 630 | 630 × 430 | 50 | 63 | 40 | 36 | 18 | 48/50 × 250 | 77 | 510 | 510 | 513 |
| 2010.6363.4. | 630 × 630 | 430 × 630 | 630 × 430 | 50 | 50 | 40 | 50 | 18 | 48/50 × 250 | 77 | 510 | 510 | 513 |
| 2010.7140.1. | 710 × 400 | 510 × 400 | 710 × 200 | 63 | 63 | 40 | 36 | 18 | 48/50 × 280 | 77 | 590 | 280 | 593 |
| 2010.7140.2. | 710 × 400 | 510 × 400 | 710 × 200 | 63 | 50 | 40 | 50 | 18 | 48/50 × 280 | 77 | 590 | 280 | 593 |
| 2010.7140.3. | 710 × 400 | 510 × 400 | 710 × 200 | 50 | 63 | 40 | 36 | 18 | 48/50 × 250 | 77 | 590 | 280 | 593 |
| 2010.7140.4. | 710 × 400 | 510 × 400 | 710 × 200 | 50 | 50 | 40 | 50 | 18 | 48/50 × 250 | 77 | 590 | 280 | 593 |
| 2010.7150.1. | 710 × 500 | 510 × 500 | 710 × 300 | 63 | 63 | 40 | 36 | 18 | 48/50 × 280 | 77 | 590 | 380 | 593 |
| 2010.7150.2. | 710 × 500 | 510 × 500 | 710 × 300 | 63 | 50 | 40 | 50 | 18 | 48/50 × 280 | 77 | 590 | 380 | 593 |
| 2010.7150.3. | 710 × 500 | 510 × 500 | 710 × 300 | 50 | 63 | 40 | 36 | 18 | 48/50 × 250 | 77 | 590 | 380 | 593 |
| 2010.7150.4. | 710 × 500 | 510 × 500 | 710 × 300 | 50 | 50 | 40 | 50 | 18 | 48/50 × 250 | 77 | 590 | 380 | 593 |
| 2010.7163.1. | 710 × 630 | 510 × 630 | 710 × 430 | 63 | 63 | 40 | 36 | 18 | 48/50 × 280 | 77 | 590 | 510 | 593 |
| 2010.7163.2. | 710 × 630 | 510 × 630 | 710 × 430 | 63 | 50 | 40 | 50 | 18 | 48/50 × 280 | 77 | 590 | 510 | 593 |
| 2010.7163.3. | 710 × 630 | 510 × 630 | 710 × 430 | 50 | 63 | 40 | 36 | 18 | 48/50 × 250 | 77 | 590 | 510 | 593 |
| 2010.7163.4. | 710 × 630 | 510 × 630 | 710 × 430 | 50 | 50 | 40 | 50 | 18 | 48/50 × 250 | 77 | 590 | 510 | 593 |
| 2010.8040.1. | 800 × 400 | 600 × 400 | 800 × 200 | 63 | 63 | 40 | 36 | 18 | 48/50 × 280 | 77 | 680 | 280 | 683 |
| 2010.8040.2. | 800 × 400 | 600 × 400 | 800 × 200 | 63 | 50 | 40 | 50 | 18 | 48/50 × 280 | 77 | 680 | 280 | 683 |
| 2010.8040.3. | 800 × 400 | 600 × 400 | 800 × 200 | 50 | 63 | 40 | 36 | 18 | 48/50 × 250 | 77 | 680 | 280 | 683 |
| 2010.8040.4. | 800 × 400 | 600 × 400 | 800 × 200 | 50 | 50 | 40 | 50 | 18 | 48/50 × 250 | 77 | 680 | 280 | 683 |
| 2010.8050.1. | 800 × 500 | 600 × 500 | 800 × 300 | 63 | 63 | 40 | 36 | 18 | 48/50 × 280 | 77 | 680 | 380 | 683 |
| 2010.8050.2. | 800 × 500 | 600 × 500 | 800 × 300 | 63 | 50 | 40 | 50 | 18 | 48/50 × 280 | 77 | 680 | 380 | 683 |
| 2010.8050.3. | 800 × 500 | 600 × 500 | 800 × 300 | 50 | 63 | 40 | 36 | 18 | 48/50 × 250 | 77 | 680 | 380 | 683 |
| 2010.8050.4. | 800 × 500 | 600 × 500 | 800 × 300 | 50 | 50 | 40 | 50 | 18 | 48/50 × 250 | 77 | 680 | 380 | 683 |
| 2010.8063.1. | 800 × 630 | 600 × 630 | 800 × 430 | 63 | 63 | 40 | 36 | 18 | 48/50 × 280 | 77 | 680 | 510 | 683 |
| 2010.8063.2. | 800 × 630 | 600 × 630 | 800 × 430 | 63 | 50 | 40 | 50 | 18 | 48/50 × 280 | 77 | 680 | 510 | 683 |
| 2010.8063.3. | 800 × 630 | 600 × 630 | 800 × 430 | 50 | 63 | 40 | 36 | 18 | 48/50 × 250 | 77 | 680 | 510 | 683 |
| 2010.8063.4. | 800 × 630 | 600 × 630 | 800 × 430 | 50 | 50 | 40 | 50 | 18 | 48/50 × 250 | 77 | 680 | 510 | 683 |

Die set to customer's specifications. Please copy this page, complete questions, and mail to FIBRO

201.45. Die set to customer's specifications Steel
201.65. Die set to customer's specifications Aluminium
without stripper

with stripper

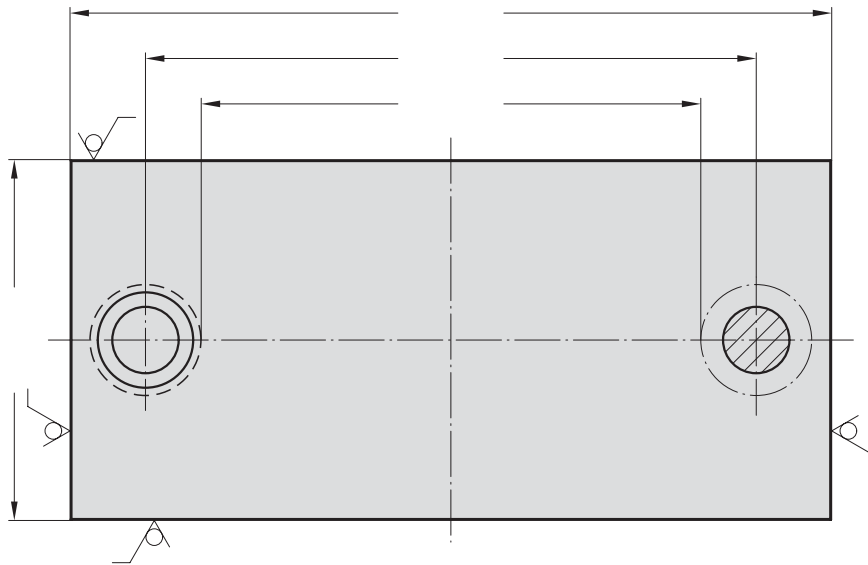
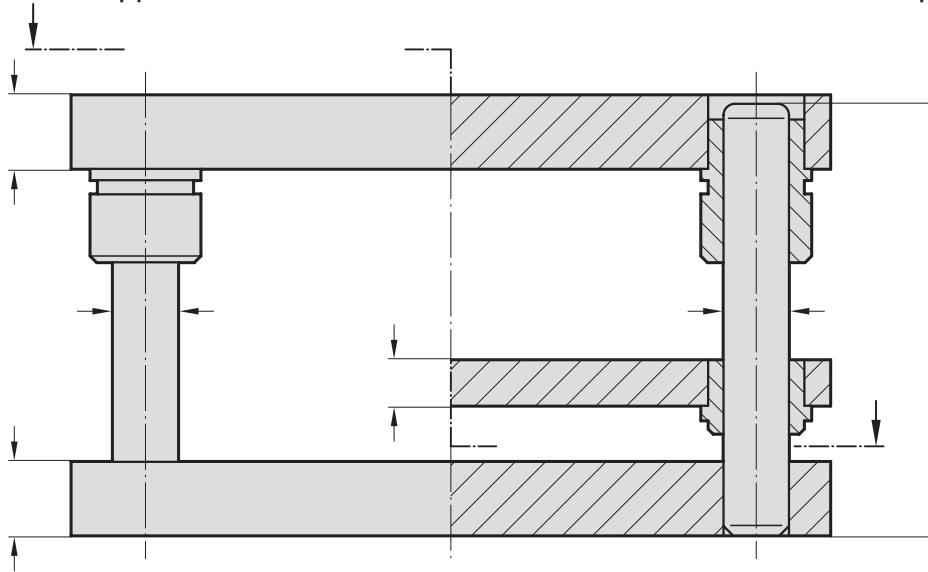

Guide Pillars
202.19. Guide Pillar
DIN 9825/ISO 9182-2

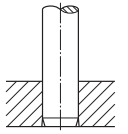

202.21. Guide Pillar
endwise bolt-on type

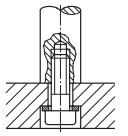

2021.46. Demountable Pillars
with collar, push fit,
screw clamp retention

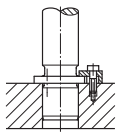

2021.46. Demountable Pillars
with collar, push fit,
screw clamp retention

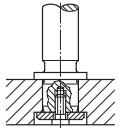

2021.43. Disc and screw

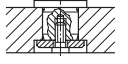

2021.50. Demountable Pillar,
conical, central screw
retention

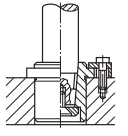

2021.39. Liner Bush

2021.53. Disc and Screw

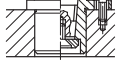

202.60. Stripper-Mounted
Pillars with Collar,
demountable, push fit,
ring nut retention

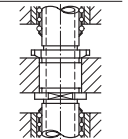

Guide Bushes

2031.34. Mounting
Flanges, rectangular;
sintered guide bush,
carbonitrided

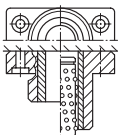

2031.42. ditto –
Ball bearing Guide Bush
206.71. Ball Cage

2031.38. Shallow Mounting Flanges,
rectangular;
sintered guide bush,
carbonitrided

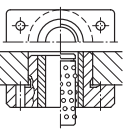

2031.44. ditto – Ball
bearing Guide Bush
206.71. Ball Cage

2051.32. Sintered Ferrite Guide Bush,
carbonitrided, bonded

2061.44. Guide Bush
for Ball Bearing Guide
206.71. Ball Cage

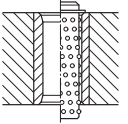

2081.31./32./33./34./35.
Headed Guide Bushes,
Sintered Ferrite,
carbonitrided

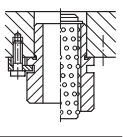

2081.44./45./46./
47./49. Guide Bushes
for Ball Bearing Guide
206.71. Ball Cage

2091.31./32./34. Flanged Guide
Bushes, Sintered Ferrite,
carbonitrided

2091.44./45./46.
Guide Bushes for Ball
Bearing Guide, push fit
206.71. Ball Cage

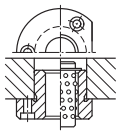

| | |
|---|--|
| Enquiry <input type="checkbox"/> Order <input type="checkbox"/> | |
| Material: Aluminium <input type="checkbox"/> 201.65. | Steel <input type="checkbox"/> 201.45. |
| Company | Telephone |
| Name (ref. for replies) | Signature |

Die set to customer's specifications.

Please copy this page, complete questions, and mail to FIBRO

Guide Pillars

202.19. Guide Pillar
DIN 9825/ISO 9182-2

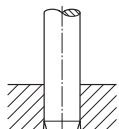

201.46. Die set to customer's specifications Steel
201.66. Die set to customer's specifications Aluminium
without stripper with stripper

202.21. Guide Pillar
endwise bolt-on type

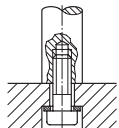

201.46. Demountable Pillars
with collar, push fit,
screw clamp retention

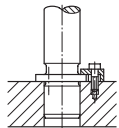

201.46. Demountable Pillars
with collar, push fit,
screw clamp retention

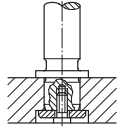

201.43. Disc and screw

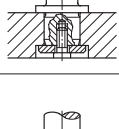

201.50. Demountable Pillar,
conical, central screw
retention

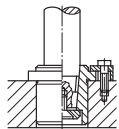

201.39. Liner Bush
201.53. Disc and Screw



202.60. Stripper-Mounted
Pillars with Collar,
demountable, push fit,
ring nut retention

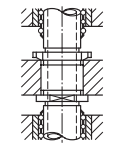

Guide Bushes

2031.34. Mounting
Flanges, rectangular;
sintered guide bush,
carbonitrided
2031.42. ditto -
Ball bearing Guide Bush
206.71. Ball Cage

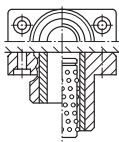

2031.38. Shallow Mounting
Flanges, rectangular;
sintered guide
bush, carbonitrided

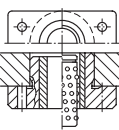

2031.44. ditto - Ball
bearing Guide Bush
206.71. Ball Cage

2051.32. Sintered Ferrite Guide
Bush, carbonitrided, bonded

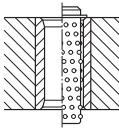

2061.44. Guide Bush
for Ball Bearing Guide
206.71. Ball Cage

2081.31./32./33./34./35.
Headed Guide Bushes,
Sintered Ferrite,
carbonitrided

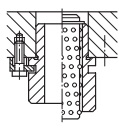

2081.44./45./46./
.47./49. Guide Bushes
for Ball Bearing Guide
206.71. Ball Cage

2091.31./32./34. Flanged Guide
Bushes, Sintered Ferrite,
carbonitrided

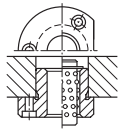

2091.44./45./46.
Guide Bushes for Ball
Bearing Guide, push fit
206.71. Ball Cage

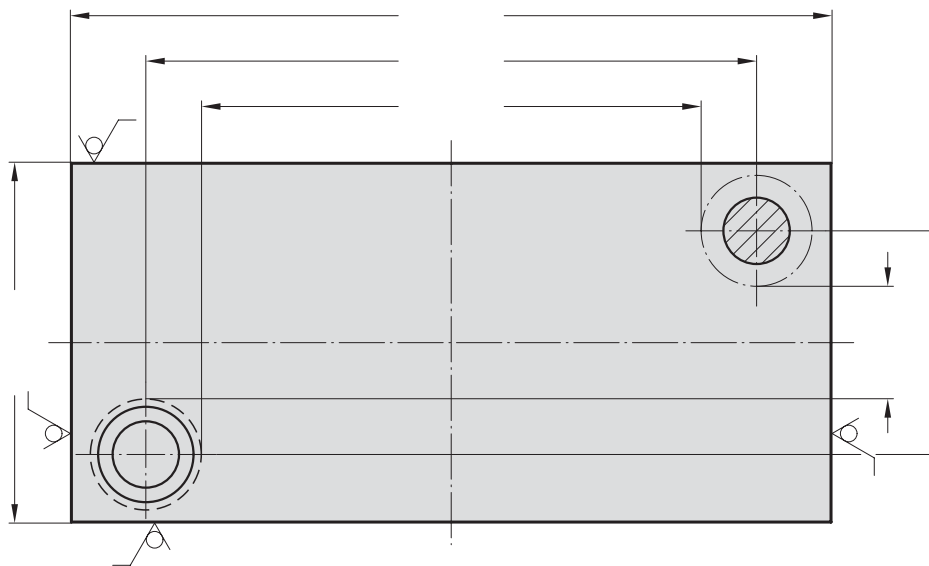
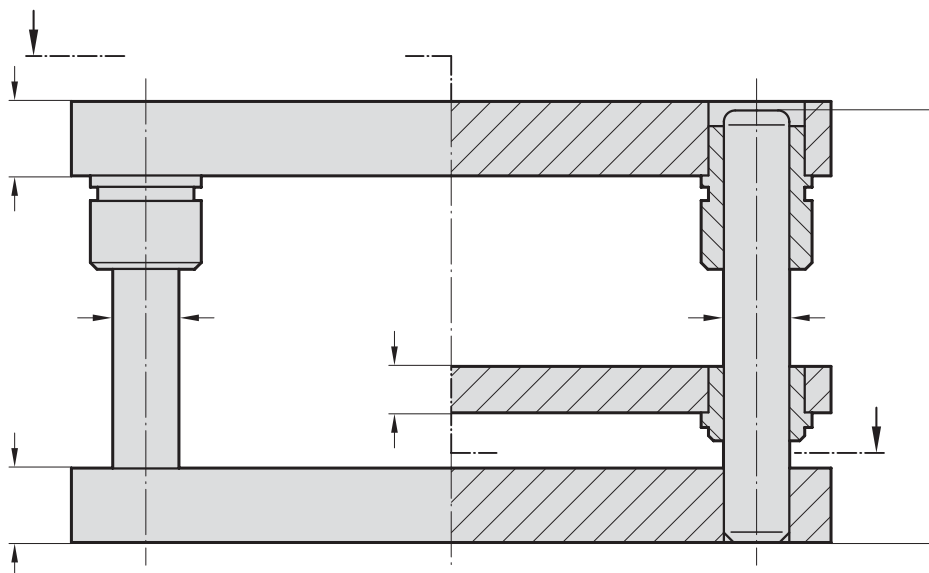

| | |
|---|--|
| Enquiry <input type="checkbox"/> Order <input type="checkbox"/> | |
| Material: Aluminium <input type="checkbox"/> 201.66. | Steel <input type="checkbox"/> 201.46. |
| Company | Telephone |
| | |
| Name (ref. for replies) | Signature |

Die set to customer's specifications. Please copy this page, complete questions, and mail to FIBRO

201.47. Die set to customer's specifications Steel
201.67. Die set to customer's specifications Aluminium
without stripper

with stripper

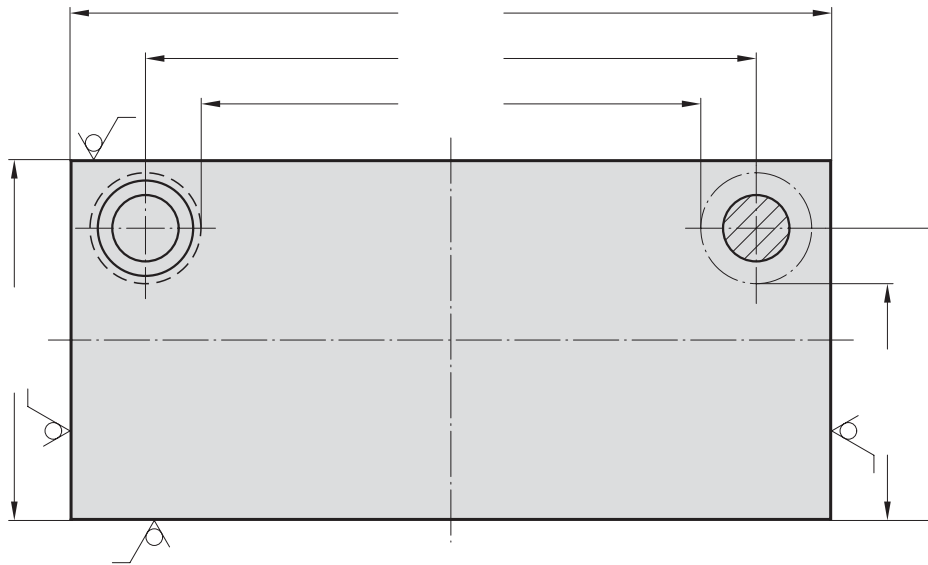
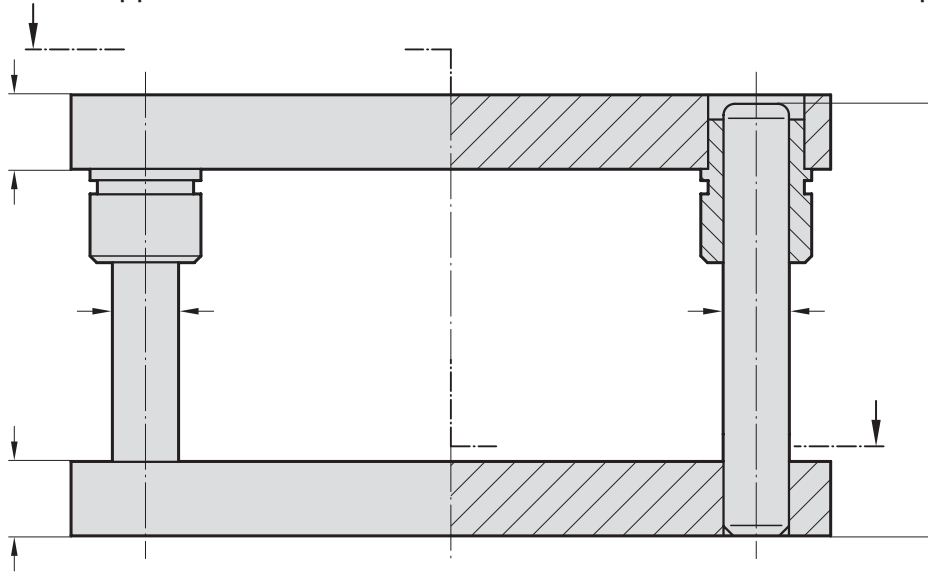

Guide Pillars

202.19. Guide Pillar
DIN 9825/ISO 9182-2

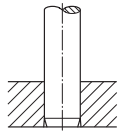

202.21. Guide Pillar
endwise bolt-on type

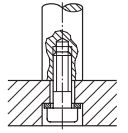

2021.46. Demountable Pillars
with collar, push fit,
screw clamp retention

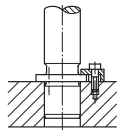

2021.46. Demountable Pillars
with collar, push fit,
screw clamp retention

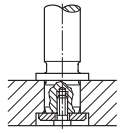

2021.43. Disc and screw



2021.50. Demountable Pillar,
conical, central screw
retention

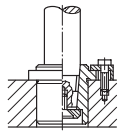

2021.39. Liner Bush

2021.53. Disc and Screw

Guide Bushes

2031.34. Mounting
Flanges, rectangular;
sintered guide bush,
carbonitrided

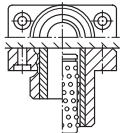

2031.42. ditto -
Ball bearing Guide Bush
206.71. Ball Cage

2031.38. Shallow Mounting
Flanges, rectangular;
sintered guide
bush, carbonitrided

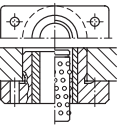

2031.44. ditto - Ball
bearing Guide Bush

206.71. Ball Cage

2051.32. Sintered Ferrite Guide
Bush, carbonitrided, bonded

2061.44. Guide Bush
for Ball Bearing Guide

206.71. Ball Cage

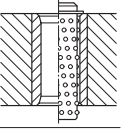

2081.31./32./33./34./35.
Headed Guide Bushes,
Sintered Ferrite,
carbonitrided

2081.44./45./46./
47./49. Guide Bushes
for Ball Bearing Guide
206.71. Ball Cage

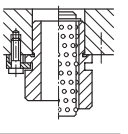

2091.31./32./34. Flanged Guide
Bushes, Sintered Ferrite,
carbonitrided

2091.44./45./46.
Guide Bushes for Ball
Bearing Guide, push fit
206.71. Ball Cage

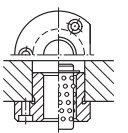

| | |
|---|--|
| Enquiry <input type="checkbox"/> Order <input type="checkbox"/> | |
| Material: Aluminium <input type="checkbox"/> 201.67. | Steel <input type="checkbox"/> 201.47. |
| Company | Telephone |
| | |
| Name (ref. for replies) | Signature |

Die set to costumer's specifications.

Please copy this page, complete questions, and mail to FIBRO

Guide Pillars

202.19. Guide Pillar
DIN 9825/ISO 9182-2

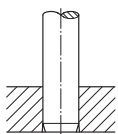

201.49. Die set to costumer's specifications Steel
201.69. Die set to costumer's specifications Aluminium
without stripper with stripper

202.21. Guide Pillar
endwise bolt-on type

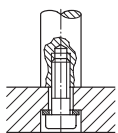

2021.46. Demountable Pillars
with collar, push fit,
screw clamp retention

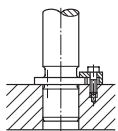

2021.46. Demountable Pillars
with collar, push fit,
screw clamp retention

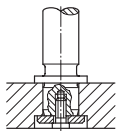

2021.43. Disc and screw

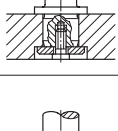

2021.50. Demountable Pillar,
conical, central screw
retention

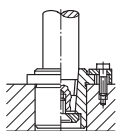

2021.39. Liner Bush

2021.53. Disc and Screw

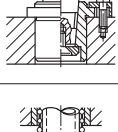

202.60. Stripper-Mounted
Pillars with Collar,
demountable, push fit,
ring nut retention

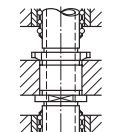

Guide Bushes

2031.34. Mounting
Flanges, rectangular;
sintered guide bush,
carbonitrided

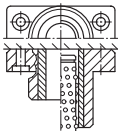

2031.42. ditto - Ball bearing Guide Bush

206.71. Ball Cage

2031.38. Shallow Mounting
Flanges, rectangular;
sintered guide
bush, carbonitrided

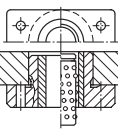

2031.44. ditto - Ball bearing Guide Bush

206.71. Ball Cage

2051.32. Sintered Ferrite Guide
Bush, carbonitrided, bonded

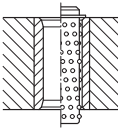

2061.44. Guide Bush
for Ball Bearing Guide

206.71. Ball Cage

2081.31./32./33./34./35. Headed Guide Bushes,
Sintered Ferrite,
carbonitrided

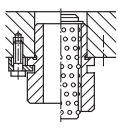

2081.44./45./46./47./49. Guide Bushes
for Ball Bearing Guide

206.71. Ball Cage

2091.31./32./34. Flanged Guide
Bushes, Sintered Ferrite,
carbonitrided

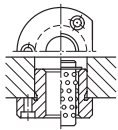

2091.44./45./46. Guide Bushes for Ball
Bearing Guide, push fit

206.71. Ball Cage

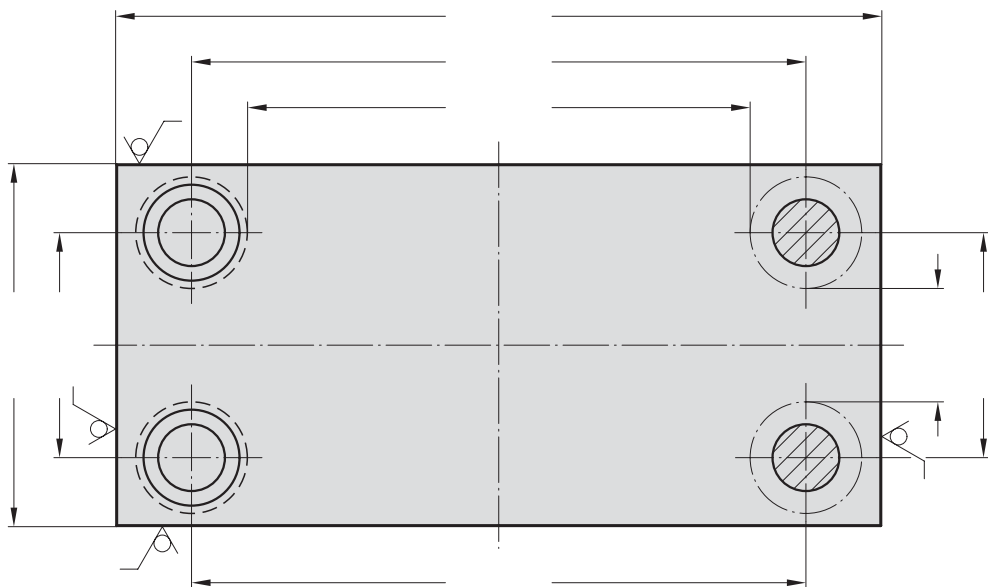
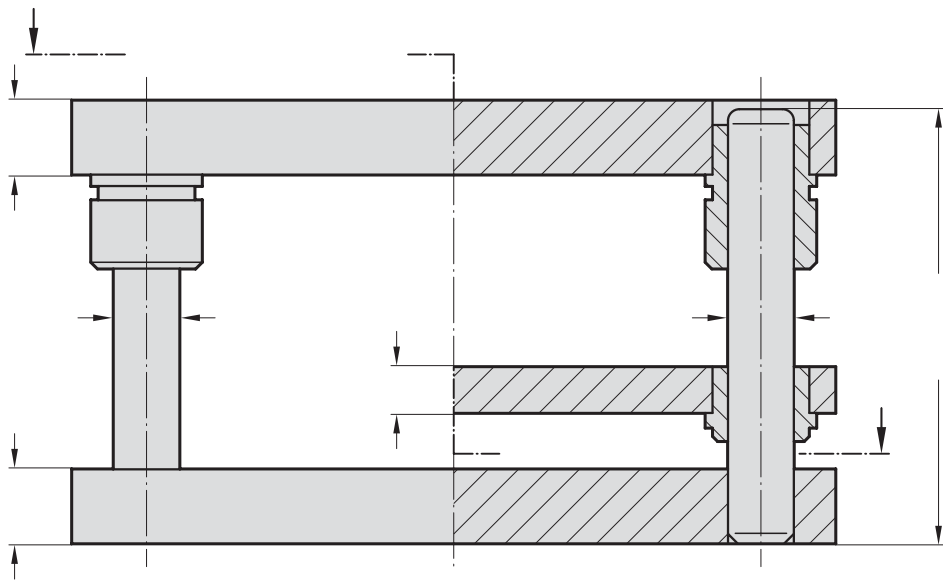

| | |
|---|--|
| Enquiry <input type="checkbox"/> Order <input type="checkbox"/> | |
| Material: Aluminium <input type="checkbox"/> 201.69. | Steel <input type="checkbox"/> 201.49. |
| Company | Telephone |
| Name (ref. for replies) | |
| Signature | |

Die set without / with stripper *ECO-LINE*

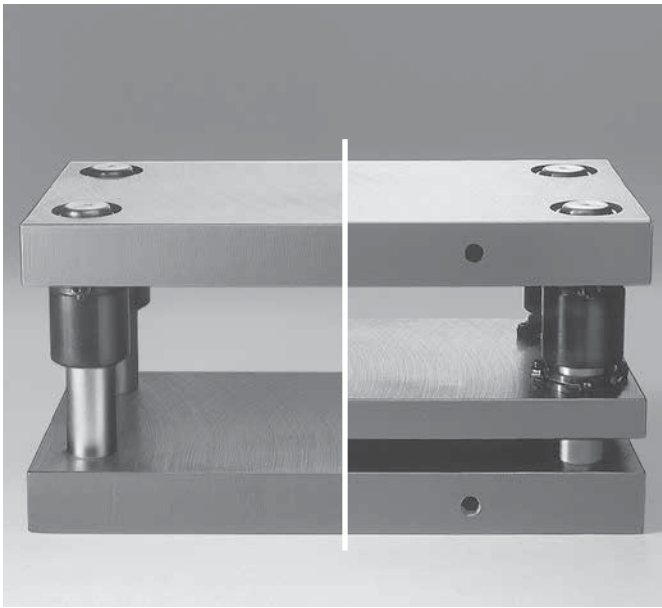

without Stripper

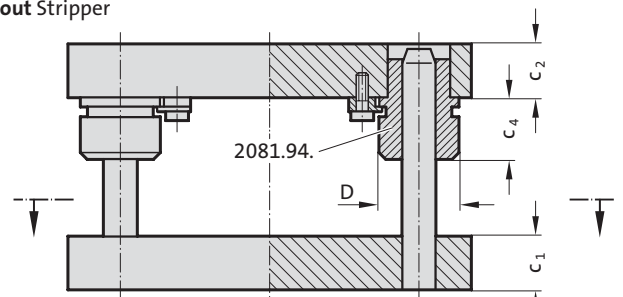

with Stripper

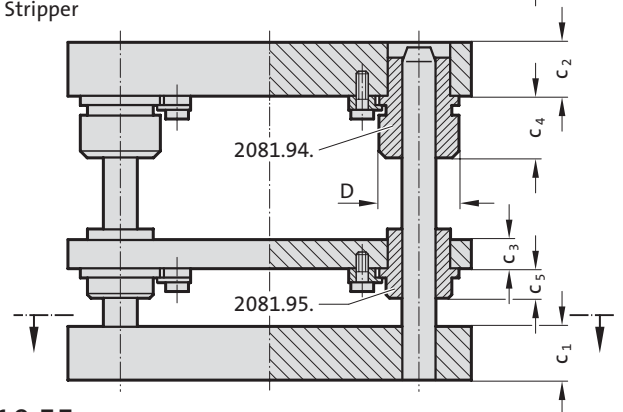

Executions:

With press-fitted guide pillars 202.29.

Headed Guide Bushes bronze plated **without** stripper

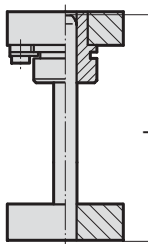

2010.5□.□□□□.□.894

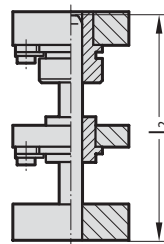

Headed Guide Bushes bronze plated **with** stripper

2010.5□.□□□□.□.895

With demountable guide pillars 2021.29.***

Headed Guide Bushes bronze plated **without** stripper

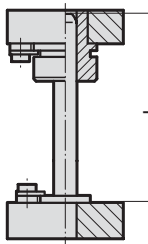

2010.5□.□□□□.□.894.29

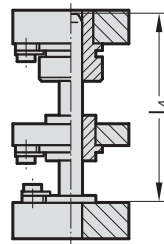

Headed Guide Bushes bronze plated **with** stripper

2010.5□.□□□□.□.895.29

2010.55.

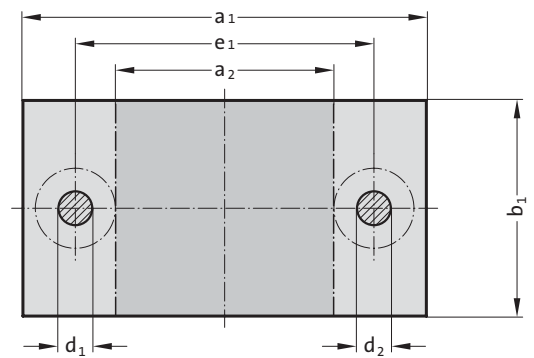

2010.57.

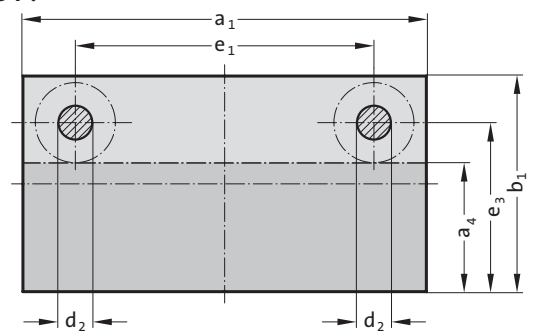

2010.59.

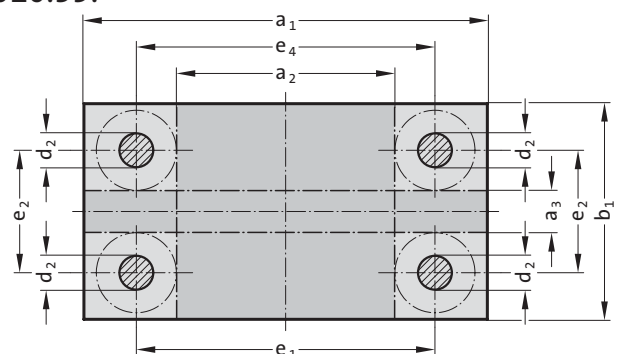

Description:

FIBRO 2010.5x all-steel die sets are supplied with bronze plated guide bushes. These are supplied in push-fit bolster bores and retained by screw clamps.

Execution:

External contours milled
Thickness surfaces ground

Note:

*** to be fixed only with screw clamps



Die set without / with stripper *ECO-LINE*

2010.5□.

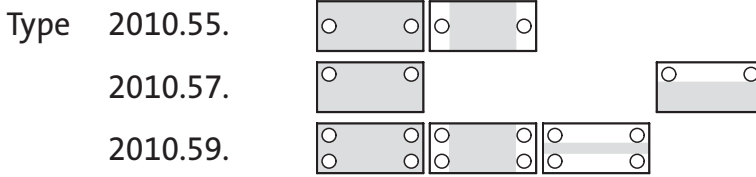

| Order No | Exe- cution | Exe- cution*** | ext. dim. | Work area(s)** | | | | c ₁ | c ₂ | c ₃ | c ₄ | c ₅ | d ₁ /d ₂ | l ₁ /l ₂ | l ₃ /l ₄ | D | e ₁ | e ₂ | e ₃ | e ₄ |
|----------|----------------|-------------------|---------------------------------|---------------------------------|---------------------------------|---------------------------------|-----------|----------------|----------------|----------------|----------------|--------------------------------|--------------------------------|--------------------------------|--------------------------------|----------------|----------------|----------------|----------------|----------------|
| Type | Size | P* | a ₁ x b ₁ | a ₂ x b ₁ | a ₁ x a ₃ | a ₁ x a ₄ | ± 2 | ± 2 | ± 2 | c ₄ | c ₅ | d ₁ /d ₂ | l ₁ /l ₂ | l ₃ /l ₄ | D | e ₁ | e ₂ | e ₃ | e ₄ | |
| 2010.55. | 2512. | 1. | 250 x 125 | 120 x 125 | - | - | 40 | 40 | 32 | 36 | 12 | 24/25 | 180/200 | 140/180 | 46 | 170 | - | - | - | |
| 2010.55. | 2512. | 4. | 250 x 125 | 120 x 125 | - | - | 32 | 32 | 32 | 36 | 12 | 24/25 | 180/200 | 140/180 | 46 | 170 | - | - | - | |
| 2010.57. | 2520. | 1. | 894 | 250 x 200 | - | - | 250 x 135 | 40 | 40 | - | 36 | - | -/25 | 180/- | 140/- | 46 | 170 | - | 160 | - |
| 2010.57. | 2520. | 4. | 894 | 250 x 200 | - | - | 250 x 135 | 32 | 32 | - | 36 | - | -/25 | 180/- | 140/- | 46 | 170 | - | 160 | - |
| 2010.59. | 2520. | 4. | 250 x 200 | 120 x 200 | 250 x 50 | - | 32 | 32 | 32 | 36 | 12 | -/25 | 180/200 | 140/180 | 46 | 170 | 120 | - | 173 | - |
| 2010.59. | 2525. | 4. | 250 x 250 | 120 x 250 | 250 x 100 | - | 32 | 32 | 32 | 36 | 12 | -/25 | 180/200 | 140/180 | 46 | 170 | 170 | - | 173 | - |
| 2010.55. | 3116. | 1. | 315 x 160 | 165 x 160 | - | - | 50 | 50 | 32 | 45 | 12 | 30/32 | 200/224 | 160/200 | 53 | 225 | - | - | - | - |
| 2010.55. | 3116. | 4. | 315 x 160 | 165 x 160 | - | - | 40 | 40 | 32 | 45 | 12 | 30/32 | 200/224 | 160/200 | 53 | 225 | - | - | - | - |
| 2010.55. | 3120. | 4. | 315 x 200 | 165 x 200 | - | - | 40 | 40 | 32 | 45 | 12 | 30/32 | 200/224 | 160/200 | 53 | 225 | - | - | - | - |
| 2010.57. | 3120. | 4. | 894 | 315 x 200 | - | - | 315 x 125 | 40 | 40 | - | 45 | - | -/32 | 200/- | 160/- | 53 | 225 | - | 155 | - |
| 2010.59. | 3120. | 4. | 315 x 200 | 165 x 200 | 315 x 30 | - | 40 | 40 | 32 | 45 | 12 | -/32 | 200/224 | 160/200 | 53 | 225 | 110 | - | 228 | - |
| 2010.57. | 3125. | 1. | 894 | 315 x 250 | - | - | 315 x 175 | 50 | 50 | - | 45 | - | -/32 | 200/- | 160/- | 53 | 225 | - | 205 | - |
| 2010.59. | 3125. | 1. | 315 x 250 | 165 x 250 | 315 x 80 | - | 50 | 50 | 32 | 45 | 12 | -/32 | 200/224 | 160/200 | 53 | 225 | 160 | - | 228 | - |
| 2010.59. | 3125. | 4. | 315 x 250 | 165 x 250 | 315 x 80 | - | 40 | 40 | 32 | 45 | 12 | -/32 | 200/224 | 160/200 | 53 | 225 | 160 | - | 228 | - |
| 2010.59. | 3131. | 1. | 315 x 315 | 165 x 315 | 315 x 145 | - | 50 | 50 | 32 | 45 | 12 | -/32 | 200/224 | 160/200 | 53 | 225 | 225 | - | 228 | - |
| 2010.55. | 4020. | 4. | 400 x 200 | 250 x 200 | - | - | 40 | 40 | 32 | 45 | 12 | 30/32 | 200/224 | 160/200 | 53 | 310 | - | - | - | - |
| 2010.59. | 4020. | 4. | 400 x 200 | 250 x 200 | 400 x 30 | - | 40 | 40 | 32 | 45 | 12 | -/32 | 200/224 | 160/200 | 53 | 310 | 110 | - | 313 | - |
| 2010.55. | 4025. | 1. | 400 x 250 | 250 x 250 | - | - | 50 | 50 | 32 | 45 | 12 | 30/32 | 200/224 | 160/200 | 53 | 310 | - | - | - | - |
| 2010.57. | 4025. | 1. | 894 | 400 x 250 | - | - | 400 x 175 | 50 | 50 | - | 45 | - | -/32 | 200/- | 160/- | 53 | 310 | - | 205 | - |
| 2010.59. | 4025. | 1. | 400 x 250 | 250 x 250 | 400 x 80 | - | 50 | 50 | 32 | 45 | 12 | -/32 | 200/224 | 160/200 | 53 | 310 | 160 | - | 313 | - |
| 2010.59. | 4025. | 4. | 400 x 250 | 250 x 250 | 400 x 80 | - | 40 | 40 | 32 | 45 | 12 | -/32 | 200/224 | 160/200 | 53 | 310 | 160 | - | 313 | - |
| 2010.57. | 4031. | 4. | 894 | 400 x 315 | - | - | 400 x 240 | 40 | 40 | - | 45 | - | -/32 | 200/- | 160/- | 53 | 310 | - | 270 | - |
| 2010.59. | 4031. | 1. | 400 x 315 | 250 x 315 | 400 x 145 | - | 50 | 50 | 32 | 45 | 12 | -/32 | 200/224 | 160/200 | 53 | 310 | 225 | - | 313 | - |
| 2010.59. | 4040. | 1. | 400 x 400 | 250 x 400 | 400 x 230 | - | 50 | 50 | 32 | 45 | 12 | -/32 | 200/224 | 160/200 | 53 | 310 | 310 | - | 313 | - |
| 2010.59. | 4040. | 4. | 400 x 400 | 250 x 400 | 400 x 230 | - | 40 | 40 | 32 | 45 | 12 | -/32 | 200/224 | 160/200 | 53 | 310 | 310 | - | 313 | - |
| 2010.55. | 5025. | 1. | 500 x 250 | 325 x 250 | - | - | 50 | 50 | 32 | 45 | 15 | 38/40 | 200/224 | 160/200 | 63 | 400 | - | - | - | - |
| 2010.59. | 5025. | 1. | 500 x 250 | 325 x 250 | 500 x 75 | - | 50 | 50 | 32 | 45 | 15 | -/40 | 200/224 | 160/200 | 63 | 400 | 150 | - | 403 | - |
| 2010.59. | 5025. | 4. | 500 x 250 | 325 x 250 | 500 x 75 | - | 40 | 40 | 32 | 45 | 15 | -/40 | 200/224 | 160/200 | 63 | 400 | 150 | - | 403 | - |
| 2010.55. | 5031. | 1. | 500 x 315 | 325 x 315 | - | - | 50 | 50 | 32 | 45 | 15 | 38/40 | 200/224 | 160/200 | 63 | 400 | - | - | - | - |
| 2010.59. | 5031. | 1. | 500 x 315 | 325 x 315 | 500 x 140 | - | 50 | 50 | 32 | 45 | 15 | -/40 | 200/224 | 160/200 | 63 | 400 | 215 | - | 403 | - |
| 2010.59. | 5040. | 1. | 500 x 400 | 325 x 400 | 500 x 225 | - | 50 | 50 | 32 | 45 | 15 | -/40 | 200/224 | 160/200 | 63 | 400 | 300 | - | 403 | - |
| 2010.59. | 5050. | 1. | 500 x 500 | 325 x 500 | 500 x 325 | - | 50 | 50 | 32 | 45 | 15 | -/40 | 200/224 | 160/200 | 63 | 400 | 400 | - | 403 | - |

*Thickness combinations

**Work area dimensions are not affected by the positions of the screw clamps that retain the bushes!

***With demountable guide pillars 2021.29.



Ordering code (example):

| | | |
|--|---|-----------------------|
| Type of Die Set (external dimensions | = | 2010.55.4025.1. |
| a ₁ x b ₁ = 400 x 250; c ₁ = c ₂ = 50) | | |
| Execution with stripper | = | 895. |
| with demountable guide pillars 2021.29. | = | 29 |
| Order No | = | 2010.55.4025.1.895.29 |

Ordering code (example):

| | | |
|--|---|--------------------|
| Type of Die Set (external dimensions | = | 2010.55.4025.1. |
| a ₁ x b ₁ = 400 x 250; c ₁ = c ₂ = 50) | | |
| Execution with stripper | = | 895 |
| Order No | = | 2010.55.4025.1.895 |

Steel plate ISO 6753-1



2900.

Execution:

External contours milled. Thickness surfaces ground

Note:

l or b ≤ 630 = +0,2 / +0,4

l or b > 630 = +0,2 / +0,6

Plates from 500 × 500 mm on are manufactured with lifting thread.

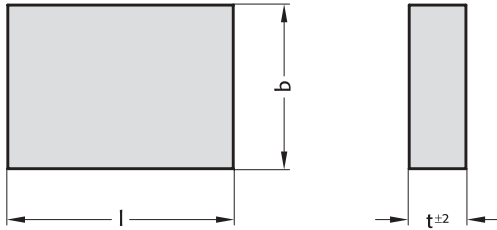

2900. Steel plate ISO 6753-1

| Order No | Size l x b x t | Order No | Size l x b x t | Order No | Size l x b x t |
|--------------|-------------------|--------------|-------------------|--------------|-------------------|
| 2900.1608.25 | 160 x 80 x 25 | 2900.3120.40 | 315 x 200 x 40 | 2900.6340.32 | 630 x 400 x 32 |
| 2900.1608.32 | 160 x 80 x 32 | 2900.3120.50 | 315 x 200 x 50 | 2900.6340.40 | 630 x 400 x 40 |
| 2900.1610.25 | 160 x 100 x 25 | 2900.3125.32 | 315 x 250 x 32 | 2900.6340.50 | 630 x 400 x 50 |
| 2900.1610.32 | 160 x 100 x 32 | 2900.3125.40 | 315 x 250 x 40 | 2900.6340.63 | 630 x 400 x 63 |
| 2900.1612.25 | 160 x 125 x 25 | 2900.3125.50 | 315 x 250 x 50 | 2900.6350.32 | 630 x 500 x 32 |
| 2900.1612.32 | 160 x 125 x 32 | 2900.3131.32 | 315 x 315 x 32 | 2900.6350.40 | 630 x 500 x 40 |
| 2900.1616.25 | 160 x 160 x 25 | 2900.3131.40 | 315 x 315 x 40 | 2900.6350.50 | 630 x 500 x 50 |
| 2900.1616.32 | 160 x 160 x 32 | 2900.3131.50 | 315 x 315 x 50 | 2900.6350.63 | 630 x 500 x 63 |
| 2900.2010.25 | 200 x 100 x 25 | 2900.4020.32 | 400 x 200 x 32 | 2900.6363.32 | 630 x 630 x 32 |
| 2900.2010.32 | 200 x 100 x 32 | 2900.4020.40 | 400 x 200 x 40 | 2900.6363.40 | 630 x 630 x 40 |
| 2900.2010.40 | 200 x 100 x 40 | 2900.4020.50 | 400 x 200 x 50 | 2900.6363.50 | 630 x 630 x 50 |
| 2900.2012.25 | 200 x 125 x 25 | 2900.4025.32 | 400 x 250 x 32 | 2900.6363.63 | 630 x 630 x 63 |
| 2900.2012.32 | 200 x 125 x 32 | 2900.4025.40 | 400 x 250 x 40 | 2900.7140.32 | 710 x 400 x 32 |
| 2900.2012.40 | 200 x 125 x 40 | 2900.4025.50 | 400 x 250 x 50 | 2900.7140.40 | 710 x 400 x 40 |
| 2900.2016.25 | 200 x 160 x 25 | 2900.4031.32 | 400 x 315 x 32 | 2900.7140.50 | 710 x 400 x 50 |
| 2900.2016.32 | 200 x 160 x 32 | 2900.4031.40 | 400 x 315 x 40 | 2900.7140.63 | 710 x 400 x 63 |
| 2900.2016.40 | 200 x 160 x 40 | 2900.4031.50 | 400 x 315 x 50 | 2900.7150.32 | 710 x 500 x 32 |
| 2900.2020.25 | 200 x 200 x 25 | 2900.4040.32 | 400 x 400 x 32 | 2900.7150.40 | 710 x 500 x 40 |
| 2900.2020.32 | 200 x 200 x 32 | 2900.4040.40 | 400 x 400 x 40 | 2900.7150.50 | 710 x 500 x 50 |
| 2900.2020.40 | 200 x 200 x 40 | 2900.4040.50 | 400 x 400 x 50 | 2900.7150.63 | 710 x 500 x 63 |
| 2900.2512.25 | 250 x 125 x 25 | 2900.5025.32 | 500 x 250 x 32 | 2900.7163.32 | 710 x 630 x 32 |
| 2900.2512.32 | 250 x 125 x 32 | 2900.5025.40 | 500 x 250 x 40 | 2900.7163.40 | 710 x 630 x 40 |
| 2900.2512.40 | 250 x 125 x 40 | 2900.5025.50 | 500 x 250 x 50 | 2900.7163.50 | 710 x 630 x 50 |
| 2900.2516.25 | 250 x 160 x 25 | 2900.5031.32 | 500 x 315 x 32 | 2900.7163.63 | 710 x 630 x 63 |
| 2900.2516.32 | 250 x 160 x 32 | 2900.5031.40 | 500 x 315 x 40 | 2900.8040.32 | 800 x 400 x 32 |
| 2900.2516.40 | 250 x 160 x 40 | 2900.5031.50 | 500 x 315 x 50 | 2900.8040.40 | 800 x 400 x 40 |
| 2900.2520.25 | 250 x 200 x 25 | 2900.5040.32 | 500 x 400 x 32 | 2900.8040.50 | 800 x 400 x 50 |
| 2900.2520.32 | 250 x 200 x 32 | 2900.5040.40 | 500 x 400 x 40 | 2900.8040.63 | 800 x 400 x 63 |
| 2900.2520.40 | 250 x 200 x 40 | 2900.5040.50 | 500 x 400 x 50 | 2900.8050.32 | 800 x 500 x 32 |
| 2900.2525.25 | 250 x 250 x 25 | 2900.5050.32 | 500 x 500 x 32 | 2900.8050.40 | 800 x 500 x 40 |
| 2900.2525.32 | 250 x 250 x 32 | 2900.5050.40 | 500 x 500 x 40 | 2900.8050.50 | 800 x 500 x 50 |
| 2900.2525.40 | 250 x 250 x 40 | 2900.5050.50 | 500 x 500 x 50 | 2900.8050.63 | 800 x 500 x 63 |
| 2900.3116.32 | 315 x 160 x 32 | 2900.6331.32 | 630 x 315 x 32 | 2900.8063.32 | 800 x 630 x 32 |
| 2900.3116.40 | 315 x 160 x 40 | 2900.6331.40 | 630 x 315 x 40 | 2900.8063.40 | 800 x 630 x 40 |
| 2900.3116.50 | 315 x 160 x 50 | 2900.6331.50 | 630 x 315 x 50 | 2900.8063.50 | 800 x 630 x 50 |
| 2900.3120.32 | 315 x 200 x 32 | 2900.6331.63 | 630 x 315 x 63 | 2900.8063.63 | 800 x 630 x 63 |



Aluminium plate ~ISO 6753-1

2910..2

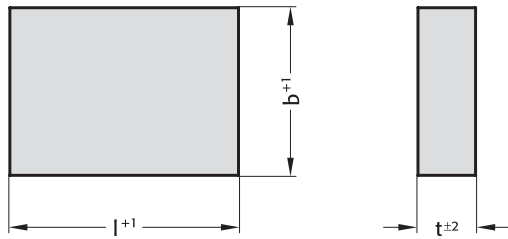

Execution:

2910.□□□□.□□.2

Two external contours milled. Thickness surfaces ground.

Note:

Plates from 500 × 500 mm on are manufactured with lifting thread.

2910..0

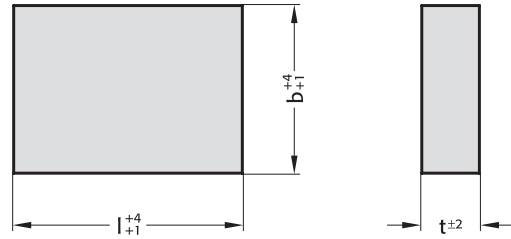

Execution:

2910.□□□□.□□.0

External contours sawed. Thickness surfaces ground.

Note:

Plates from 500 × 500 mm on are manufactured with lifting thread.

2910. Aluminium plate ~ISO 6753-1

| Order No | Size l x b x t | Order No | Size l x b x t | Order No | Size l x b x t | Order No | Size l x b x t |
|----------------|-------------------|----------------|-------------------|----------------|-------------------|----------------|-------------------|
| 2910.1608.25.□ | 160 x 80 x 25 | 2910.2520.32.□ | 250 x 200 x 32 | 2910.4040.40.□ | 400 x 400 x 40 | 2910.6363.40.□ | 630 x 630 x 40 |
| 2910.1608.32.□ | 160 x 80 x 32 | 2910.2520.40.□ | 250 x 200 x 40 | 2910.4040.50.□ | 400 x 400 x 50 | 2910.6363.50.□ | 630 x 630 x 50 |
| 2910.1610.25.□ | 160 x 100 x 25 | 2910.2525.25.□ | 250 x 250 x 25 | 2910.5025.32.□ | 500 x 250 x 32 | 2910.6363.63.□ | 630 x 630 x 63 |
| 2910.1610.32.□ | 160 x 100 x 32 | 2910.2525.32.□ | 250 x 250 x 32 | 2910.5025.40.□ | 500 x 250 x 40 | 2910.7140.32.□ | 710 x 400 x 32 |
| 2910.1612.25.□ | 160 x 125 x 25 | 2910.2525.40.□ | 250 x 250 x 40 | 2910.5025.50.□ | 500 x 250 x 50 | 2910.7140.40.□ | 710 x 400 x 40 |
| 2910.1612.32.□ | 160 x 125 x 32 | 2910.3116.32.□ | 315 x 160 x 32 | 2910.5031.32.□ | 500 x 315 x 32 | 2910.7140.50.□ | 710 x 400 x 50 |
| 2910.1616.25.□ | 160 x 160 x 25 | 2910.3116.40.□ | 315 x 160 x 40 | 2910.5031.40.□ | 500 x 315 x 40 | 2910.7140.63.□ | 710 x 400 x 63 |
| 2910.1616.32.□ | 160 x 160 x 32 | 2910.3116.50.□ | 315 x 160 x 50 | 2910.5031.50.□ | 500 x 315 x 50 | 2910.7150.32.□ | 710 x 500 x 32 |
| 2910.2010.25.□ | 200 x 100 x 25 | 2910.3120.32.□ | 315 x 200 x 32 | 2910.5040.32.□ | 500 x 400 x 32 | 2910.7150.40.□ | 710 x 500 x 40 |
| 2910.2010.32.□ | 200 x 100 x 32 | 2910.3120.40.□ | 315 x 200 x 40 | 2910.5040.40.□ | 500 x 400 x 40 | 2910.7150.50.□ | 710 x 500 x 50 |
| 2910.2010.40.□ | 200 x 100 x 40 | 2910.3120.50.□ | 315 x 200 x 50 | 2910.5040.50.□ | 500 x 400 x 50 | 2910.7150.63.□ | 710 x 500 x 63 |
| 2910.2012.25.□ | 200 x 125 x 25 | 2910.3125.32.□ | 315 x 250 x 32 | 2910.5050.32.□ | 500 x 500 x 32 | 2910.7163.32.□ | 710 x 630 x 32 |
| 2910.2012.32.□ | 200 x 125 x 32 | 2910.3125.40.□ | 315 x 250 x 40 | 2910.5050.40.□ | 500 x 500 x 40 | 2910.7163.40.□ | 710 x 630 x 40 |
| 2910.2012.40.□ | 200 x 125 x 40 | 2910.3125.50.□ | 315 x 250 x 50 | 2910.5050.50.□ | 500 x 500 x 50 | 2910.7163.50.□ | 710 x 630 x 50 |
| 2910.2016.25.□ | 200 x 160 x 25 | 2910.3131.32.□ | 315 x 315 x 32 | 2910.6331.32.□ | 630 x 315 x 32 | 2910.7163.63.□ | 710 x 630 x 63 |
| 2910.2016.32.□ | 200 x 160 x 32 | 2910.3131.40.□ | 315 x 315 x 40 | 2910.6331.40.□ | 630 x 315 x 40 | 2910.8040.32.□ | 800 x 400 x 32 |
| 2910.2016.40.□ | 200 x 160 x 40 | 2910.3131.50.□ | 315 x 315 x 50 | 2910.6331.50.□ | 630 x 315 x 50 | 2910.8040.40.□ | 800 x 400 x 40 |
| 2910.2020.25.□ | 200 x 200 x 25 | 2910.4020.32.□ | 400 x 200 x 32 | 2910.6331.63.□ | 630 x 315 x 63 | 2910.8040.50.□ | 800 x 400 x 50 |
| 2910.2020.32.□ | 200 x 200 x 32 | 2910.4020.40.□ | 400 x 200 x 40 | 2910.6340.32.□ | 630 x 400 x 32 | 2910.8040.63.□ | 800 x 400 x 63 |
| 2910.2020.40.□ | 200 x 200 x 40 | 2910.4020.50.□ | 400 x 200 x 50 | 2910.6340.40.□ | 630 x 400 x 40 | 2910.8050.32.□ | 800 x 500 x 32 |
| 2910.2512.25.□ | 250 x 125 x 25 | 2910.4025.32.□ | 400 x 250 x 32 | 2910.6340.50.□ | 630 x 400 x 50 | 2910.8050.40.□ | 800 x 500 x 40 |
| 2910.2512.32.□ | 250 x 125 x 32 | 2910.4025.40.□ | 400 x 250 x 40 | 2910.6340.63.□ | 630 x 400 x 63 | 2910.8050.50.□ | 800 x 500 x 50 |
| 2910.2512.40.□ | 250 x 125 x 40 | 2910.4025.50.□ | 400 x 250 x 50 | 2910.6350.32.□ | 630 x 500 x 32 | 2910.8050.63.□ | 800 x 500 x 63 |
| 2910.2516.25.□ | 250 x 160 x 25 | 2910.4031.32.□ | 400 x 315 x 32 | 2910.6350.40.□ | 630 x 500 x 40 | 2910.8063.32.□ | 800 x 630 x 32 |
| 2910.2516.32.□ | 250 x 160 x 32 | 2910.4031.40.□ | 400 x 315 x 40 | 2910.6350.50.□ | 630 x 500 x 50 | 2910.8063.40.□ | 800 x 630 x 40 |
| 2910.2516.40.□ | 250 x 160 x 40 | 2910.4031.50.□ | 400 x 315 x 50 | 2910.6350.63.□ | 630 x 500 x 63 | 2910.8063.50.□ | 800 x 630 x 50 |
| 2910.2520.25.□ | 250 x 200 x 25 | 2910.4040.32.□ | 400 x 400 x 32 | 2910.6363.32.□ | 630 x 630 x 32 | 2910.8063.63.□ | 800 x 630 x 63 |

Ordering Code (example):

| | |
|-----------------------------|------------------|
| Aluminium plate ~ISO 6753-1 | = 2910. |
| Length L | 160 mm = 16 |
| Width B | 80 mm = 08. |
| Thickness T | 25 mm = 25. |
| Execution FORM | sawn = 0 |
| Order No | = 2910.1608.25.0 |

Die set press unit

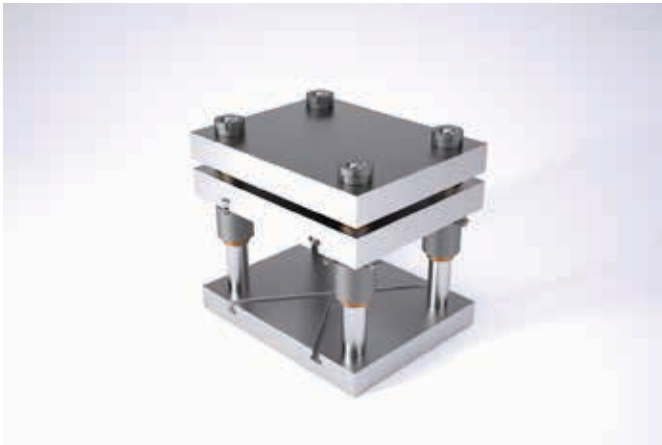

2011.45.
2011.49.

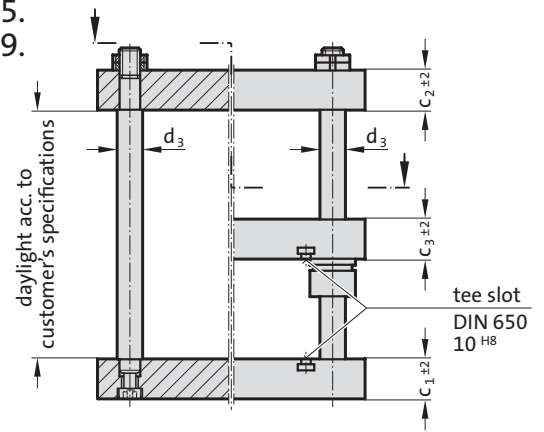

2011.49.

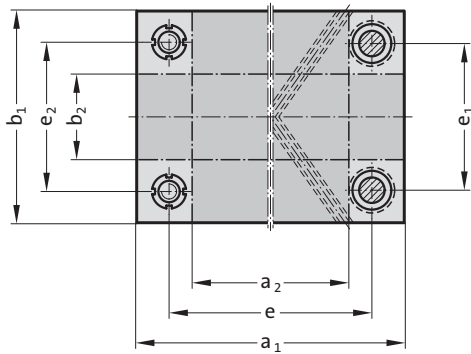

2011.45.

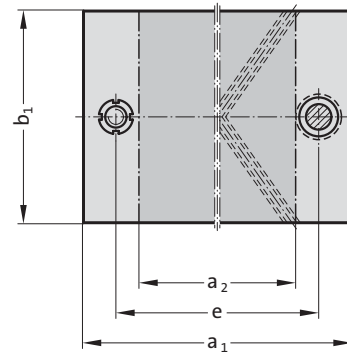

2011.45. Die set press unit

| Order No | work area | | max. press thrust kN | a ₁ | b ₁ | c ₁ | c ₂ | c ₃ | d ₃ | e | e ₁ | e ₂ |
|-------------------------|---------------------------------|---------------------------------|-------------------------|----------------|----------------|----------------|----------------|----------------|----------------|-----|----------------|----------------|
| | a ₁ × b ₂ | a ₂ × b ₁ | | | | | | | | | | |
| 2011.4□.2020.□□□.□□□□.□ | 84 × 200 | 200 × 62 | 20 | 200 | 200 | 32 | 32 | 32 | 25 | 132 | 132 | 129 |
| 2011.4□.2520.□□□.□□□□.□ | 134 × 200 | 250 × 62 | 20 | 250 | 200 | 32 | 32 | 32 | 25 | 182 | 132 | 129 |
| 2011.4□.2525.□□□.□□□□.□ | 118 × 250 | 250 × 97 | 40 | 250 | 250 | 40 | 40 | 40 | 32 | 174 | 174 | 171 |
| 2011.4□.3125.□□□.□□□□.□ | 185 × 250 | 315 × 97 | 40 | 315 | 250 | 40 | 40 | 40 | 32 | 239 | 174 | 171 |
| 2011.4□.3131.□□□.□□□□.□ | 183 × 315 | 315 × 162 | 40 | 315 | 315 | 40 | 40 | 40 | 32 | 239 | 239 | 236 |
| 2011.4□.4031.□□□.□□□□.□ | 268 × 315 | 400 × 162 | 80 | 400 | 315 | 50 | 50 | 50 | 32 | 324 | 239 | 236 |
| 2011.4□.4040.□□□.□□□□.□ | 268 × 400 | 400 × 247 | 80 | 400 | 400 | 50 | 50 | 50 | 32 | 324 | 324 | 321 |

Order number system:

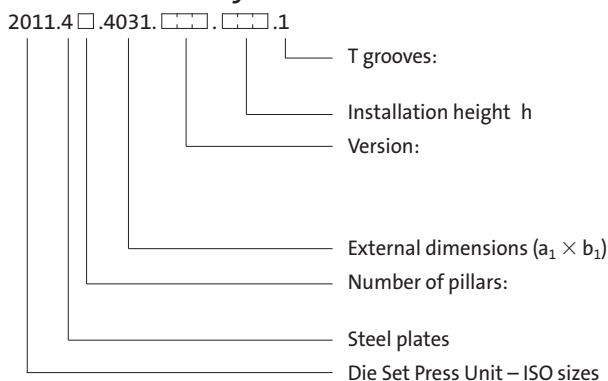

Coupling spigots and -holders between cylinder and tool:
see next page but one.

.0 = without
.1 = in top bolster and intermediate plate

000. = without guide bolster
001. = without guide bolster – tension rod not hardened
831. = guide bolster with plain bearing
862. = guide bolster with ball bearing guide

40: a₁ = 400 mm; 31: b₁ = 315 mm

5. = two guide pillars
9. = four guide pillars



Die set press unit

201.145.
201.149.

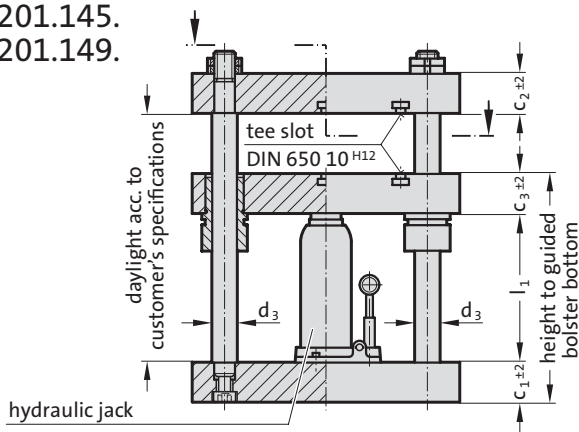

201.145.

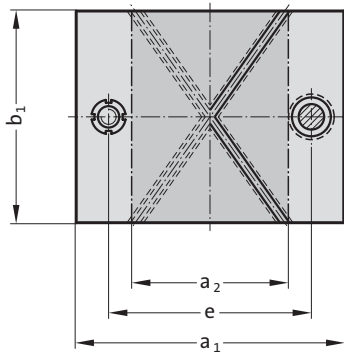

201.149.

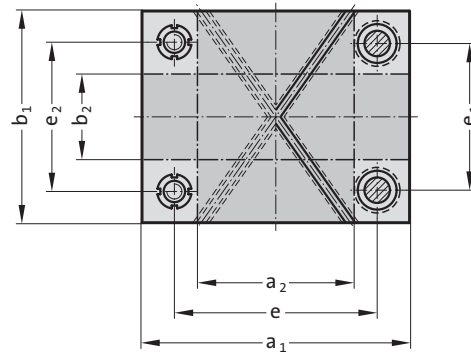

201.145. Die set press unit

| Order No | work area | work area | max. press thrust | | | | | | | | | | | | Stroke _{max.} |
|-------------------------|---------------------------------|---------------------------------|-------------------|-----|----------------|----------------|----------------|----------------|----------------|----------------|-----|----------------|----------------|----------------|------------------------|
| | a ₁ × b ₁ | a ₂ × b ₁ | | kN | a ₁ | b ₁ | c ₁ | c ₂ | c ₃ | d ₃ | e | e ₁ | e ₂ | l ₁ | |
| 201.14□.2020.□□□□□□□□□□ | 84 × 200 | 200 × 62 | 20 | 200 | 200 | 32 | 32 | 32 | 25 | 132 | 132 | 129 | 200 | 130 | |
| 201.14□.2520.□□□□□□□□□□ | 134 × 200 | 250 × 62 | 20 | 250 | 200 | 32 | 32 | 32 | 25 | 182 | 132 | 129 | 200 | 130 | |
| 201.14□.2525.□□□□□□□□□□ | 118 × 250 | 250 × 97 | 40 | 250 | 250 | 40 | 40 | 40 | 32 | 174 | 174 | 171 | 200 | 130 | |
| 201.14□.3125.□□□□□□□□□□ | 183 × 250 | 315 × 97 | 40 | 315 | 250 | 40 | 40 | 40 | 32 | 239 | 174 | 171 | 200 | 130 | |
| 201.14□.3131.□□□□□□□□□□ | 283 × 315 | 315 × 162 | 40 | 315 | 315 | 40 | 40 | 40 | 32 | 239 | 239 | 236 | 200 | 130 | |
| 201.14□.4031.□□□□□□□□□□ | 268 × 315 | 400 × 162 | 80 | 400 | 315 | 50 | 50 | 50 | 32 | 324 | 239 | 236 | 245 | 160 | |
| 201.14□.4040.□□□□□□□□□□ | 268 × 400 | 400 × 247 | 80 | 400 | 400 | 50 | 50 | 50 | 32 | 324 | 324 | 321 | 245 | 160 | |

Order number system:

201.14□.4031.□□□□□□□□□□.1

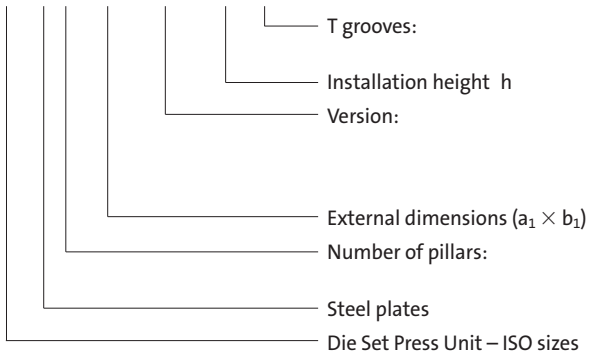

Execution: Headed guide bushes, hydraulic jack.

.0 = without
.1 = in top bolster and intermediate plate

831. = guide bolster with plain bearing
862. = guide bolster with ball bearing guide

40: a₁ = 400 mm; 31: b₁ = 315 mm

5. = two guide pillars
9. = four guide pillars

Die Set Press Unit-Accessories

Coupling Spigot Holder

Coupling Spigot



212.16.1.

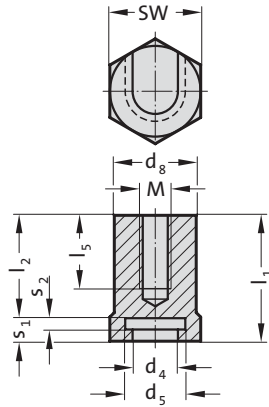

212.16.1. Coupling Spigot Holder

| Order No | d ₄ | d ₅ | d ₈ | SW | l ₁ | l ₂ | l ₅ * | M* | s ₁ | s ₂ |
|--------------|----------------|----------------|----------------|----|----------------|----------------|------------------|----|----------------|----------------|
| 212.16.1.026 | 26 | 33 | 45 | 50 | 70 | 57,4 | | | 12,6 | 7 |
| 212.16.1.033 | 33 | 49 | 60 | 65 | 86 | 67,4 | | | 18,6 | 10 |

* upon customer's specification



212.11.

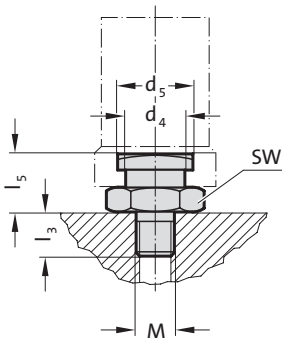

212.11. Coupling Spigot

| Order No | M | d ₄ | d ₅ | l ₃ | l ₅ | SW |
|------------|-----------|----------------|----------------|----------------|----------------|----|
| 212.11.016 | M16 × 1.5 | 25 | 32 | 18 | 23 | 36 |
| 212.11.030 | M30 × 2 | 32 | 48 | 30 | 43 | 60 |



212.15.

4 socket cap screws
M8 x 25
DIN EN ISO 4762

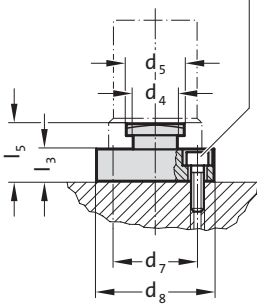

212.15. Coupling Spigot

| Order No | d ₄ | d ₅ | d ₈ | d ₇ | l ₃ | l ₅ |
|------------|----------------|----------------|----------------|----------------|----------------|----------------|
| 212.15.063 | 25 | 32 | 63 | 46 | 18 | 31 |
| 212.15.080 | 32 | 48 | 80 | 63 | 18 | 37 |



Special Die Set (All-Steel) to Customers' Specification

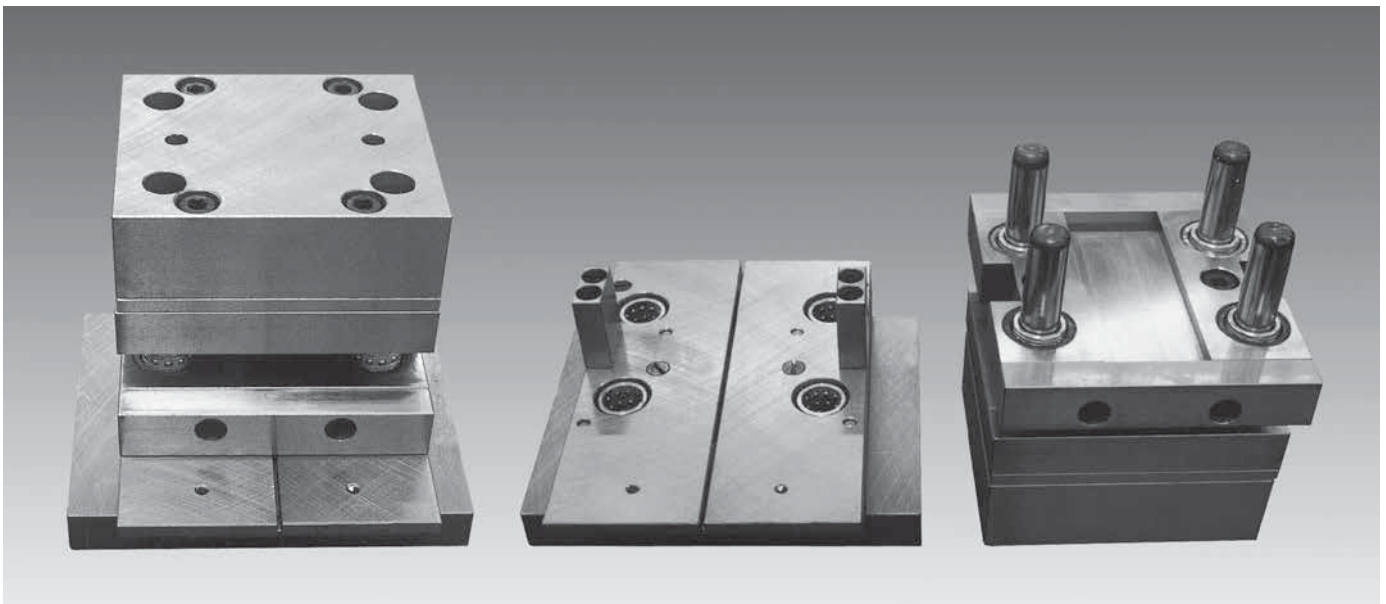
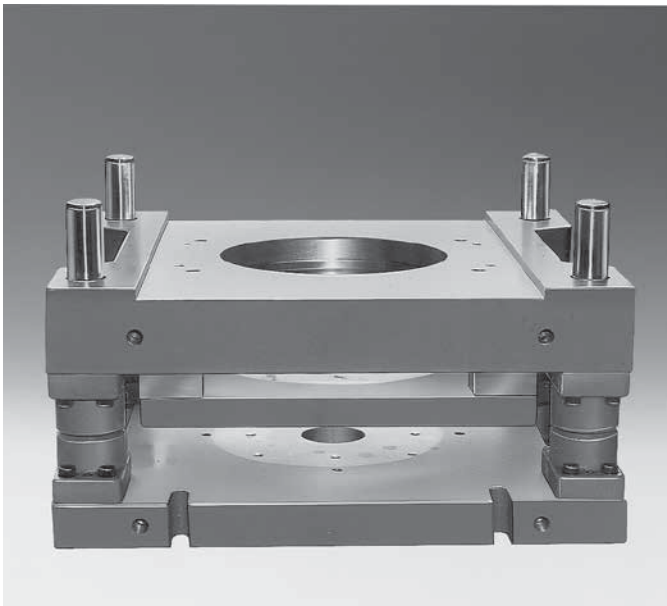
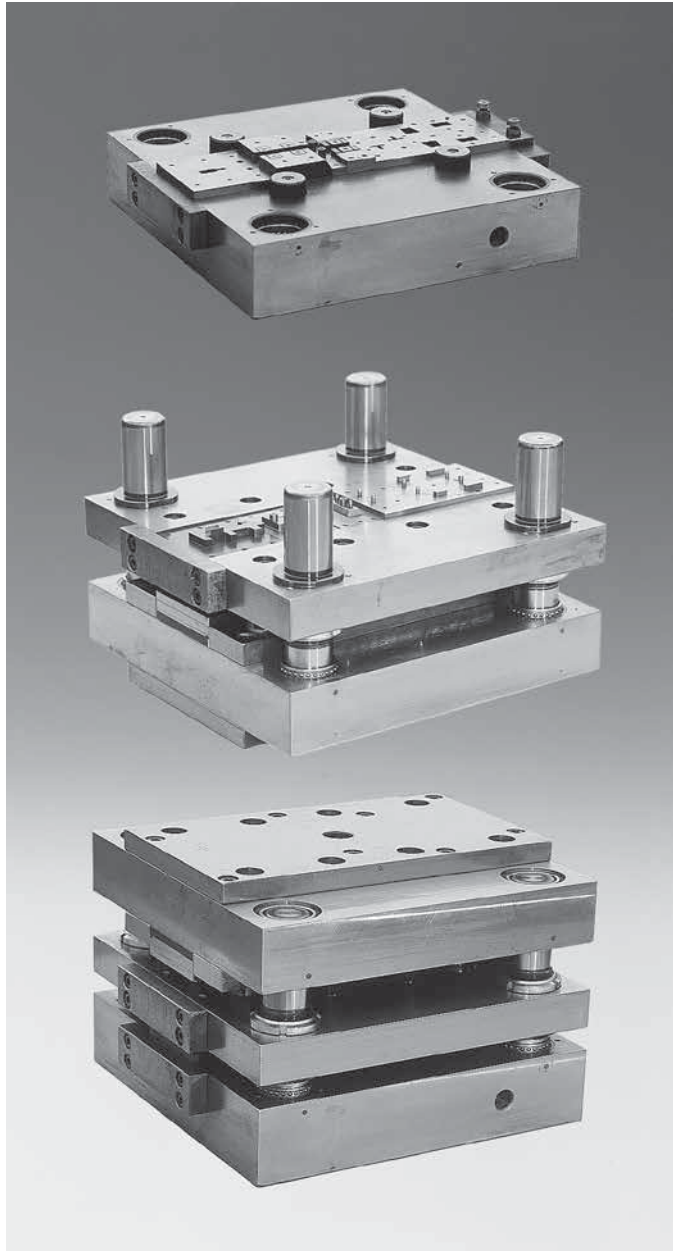
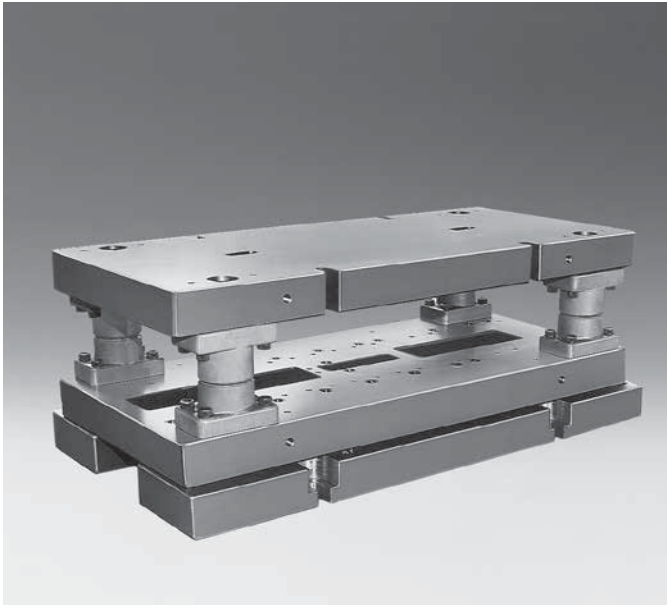

Special Die Set (All-Steel) to Customers' Specification

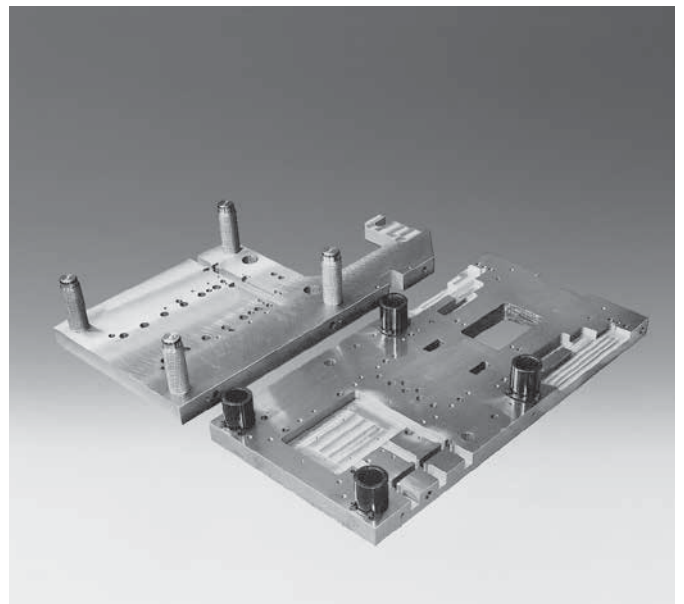
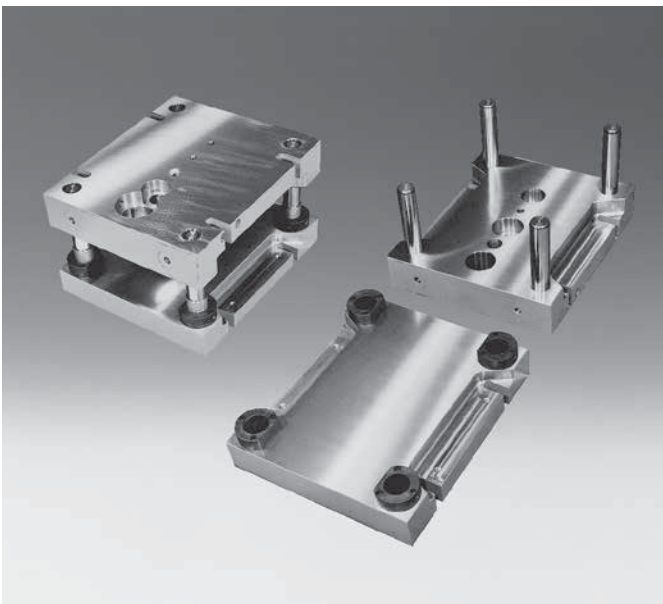
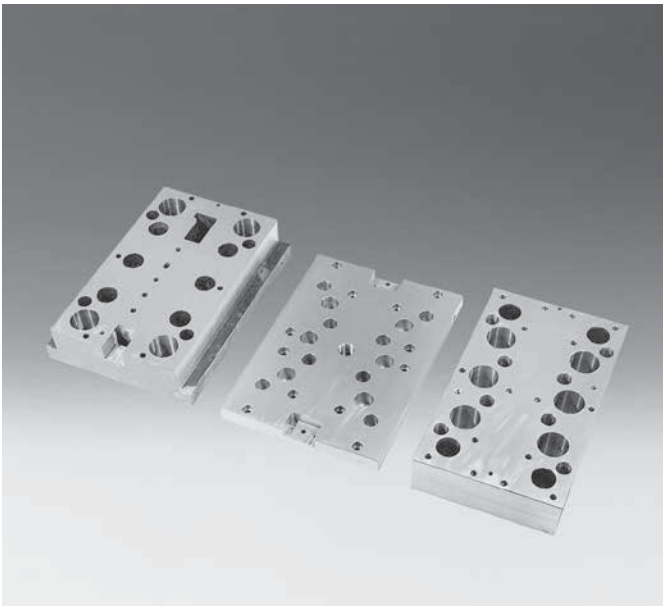
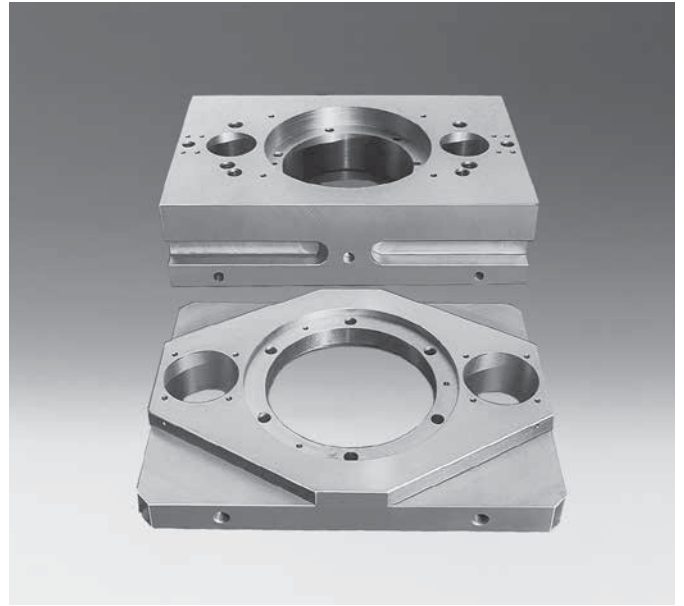
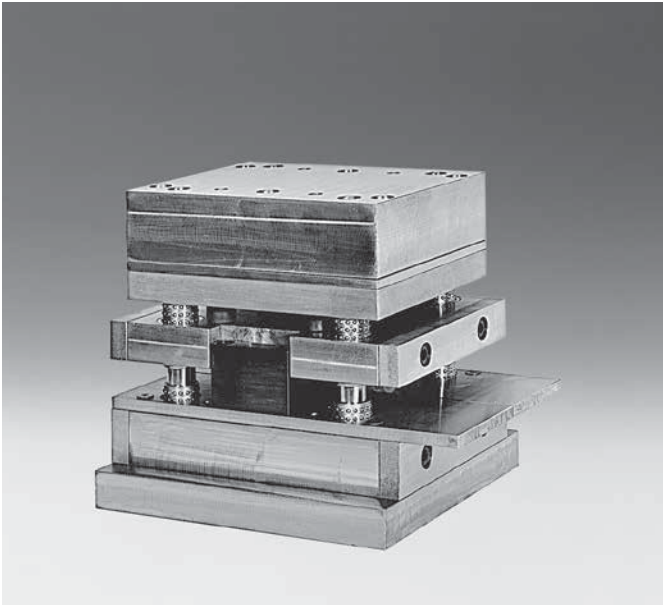

Special Die Set (All-Steel) to Customers' Specification

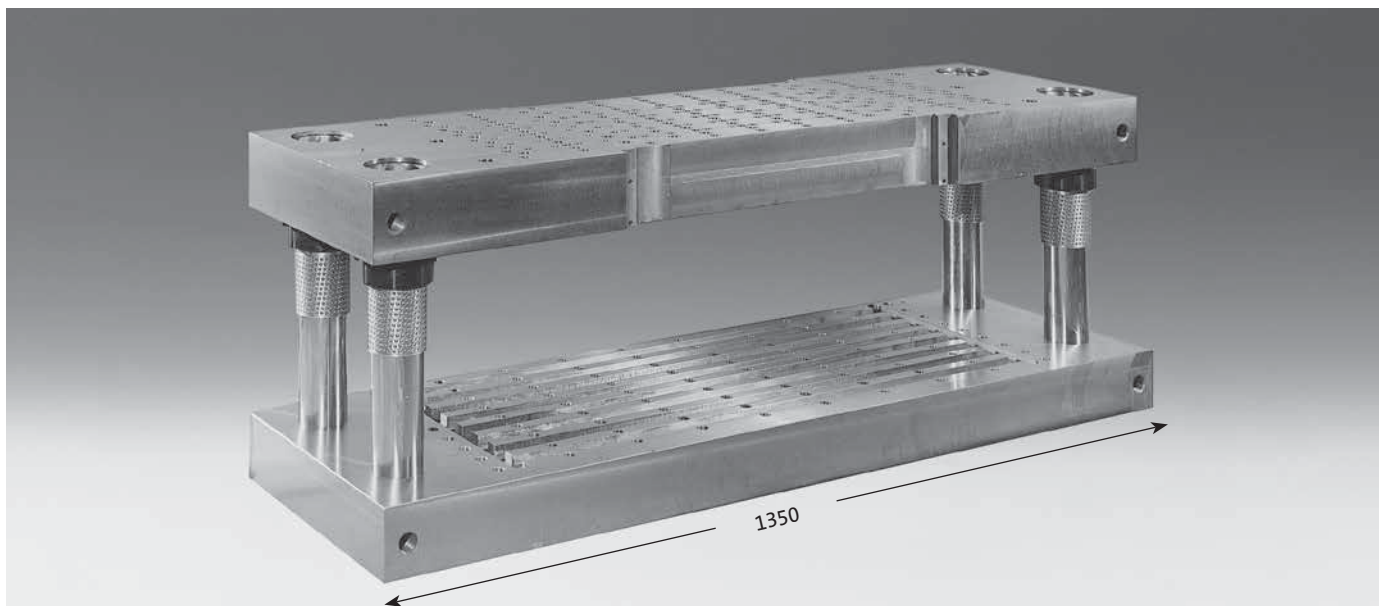
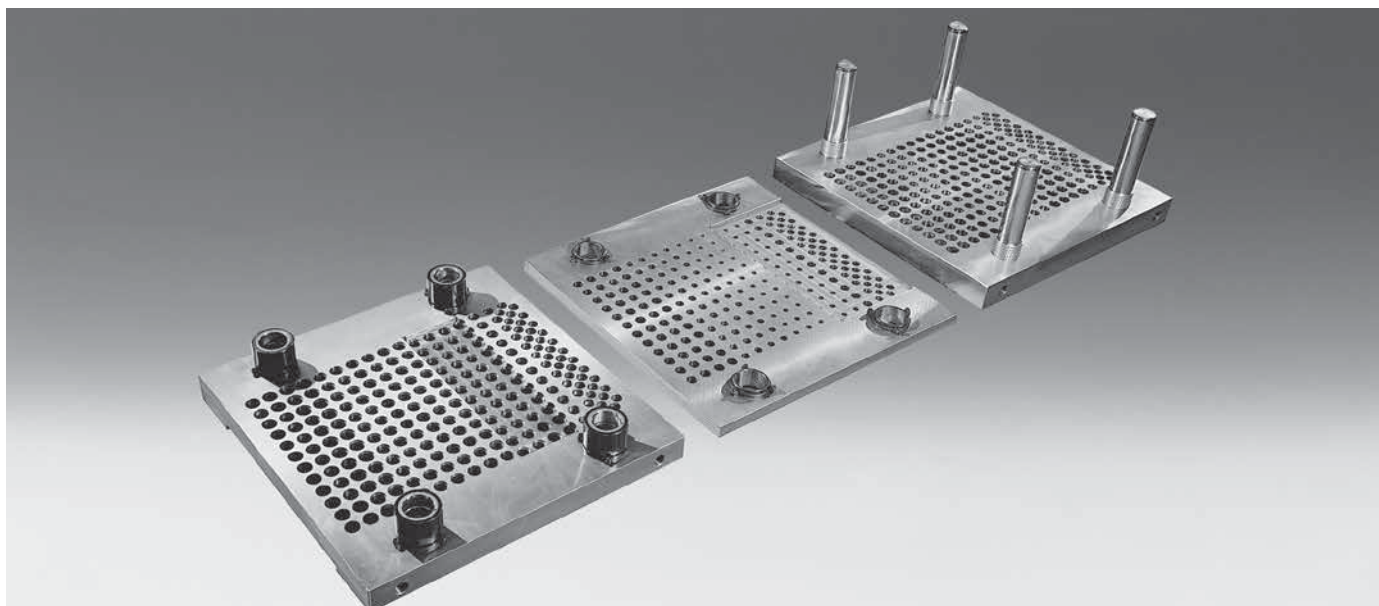
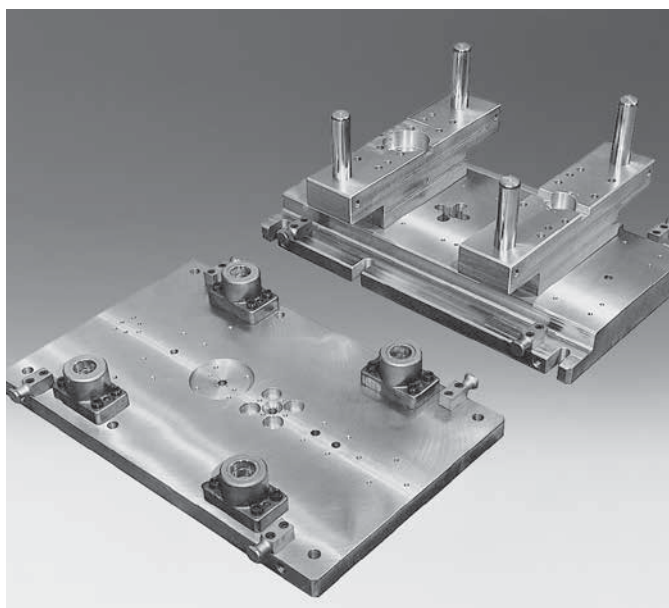
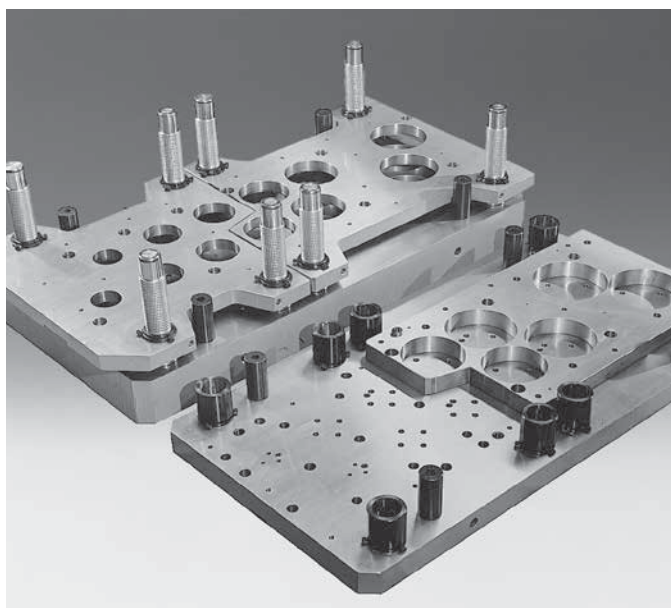

Special Die Set (All-Steel) to Customers' Specification

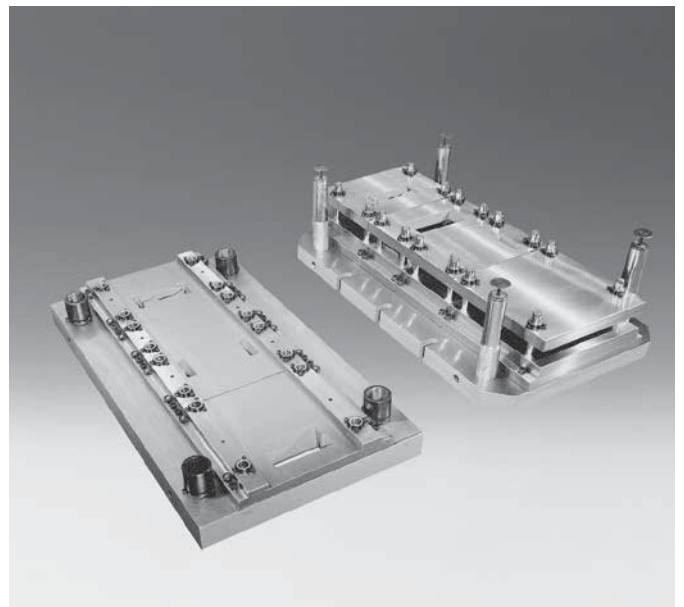
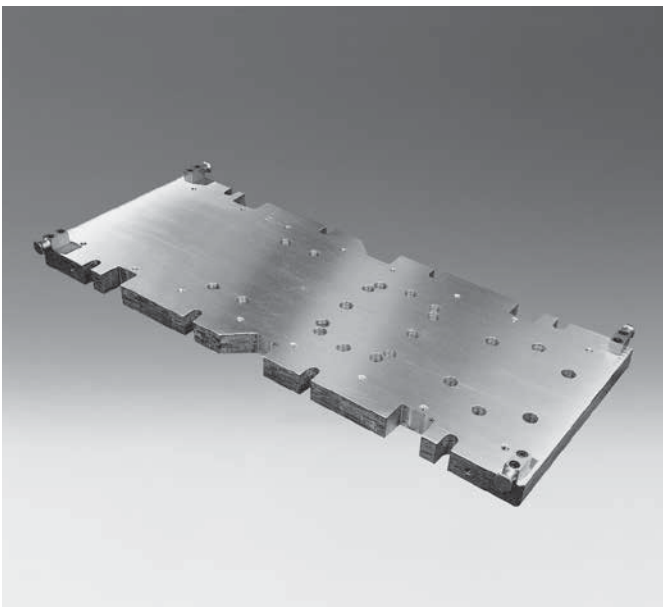
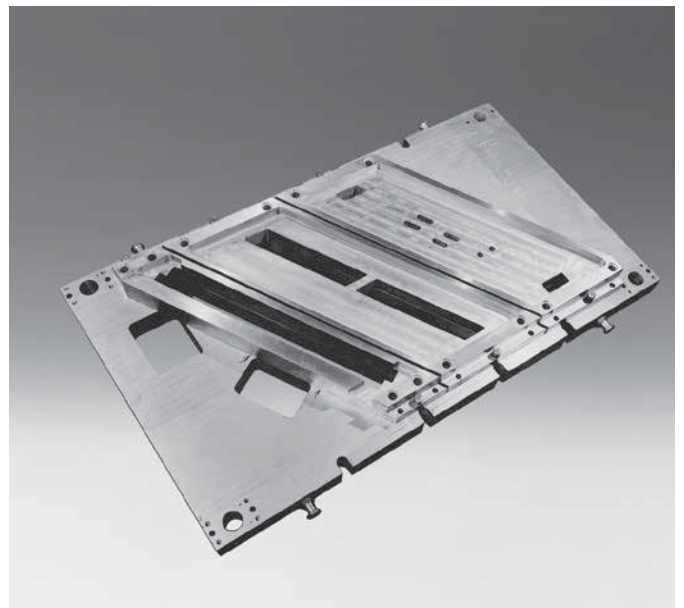
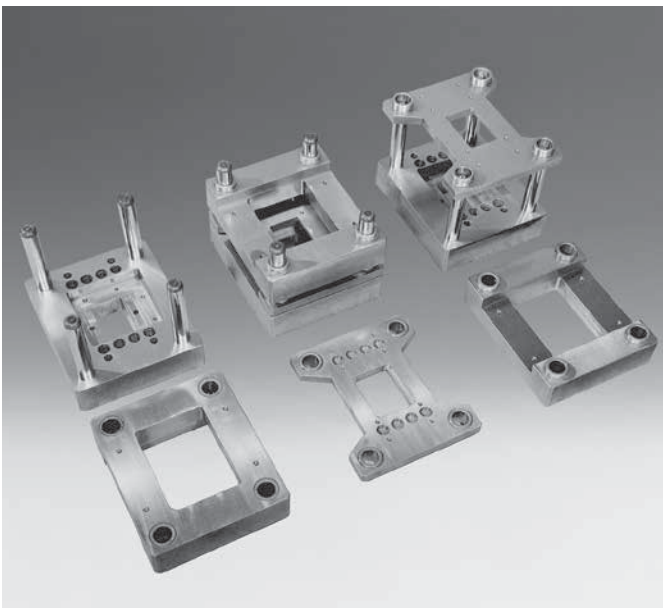
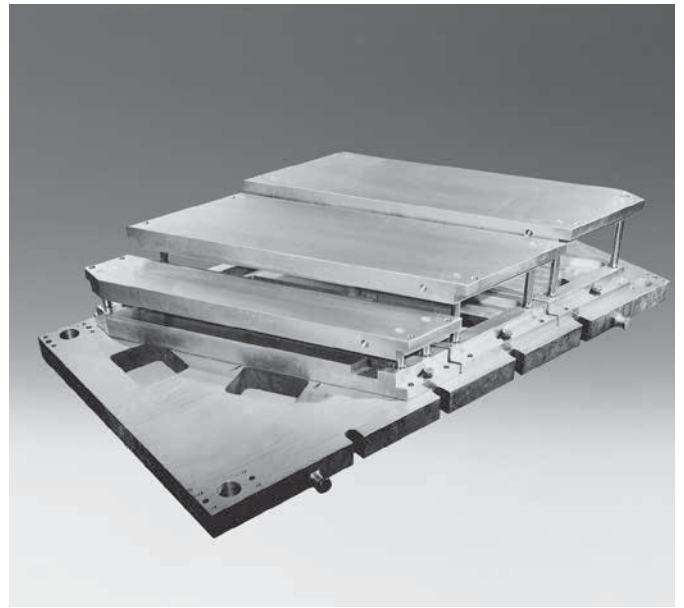
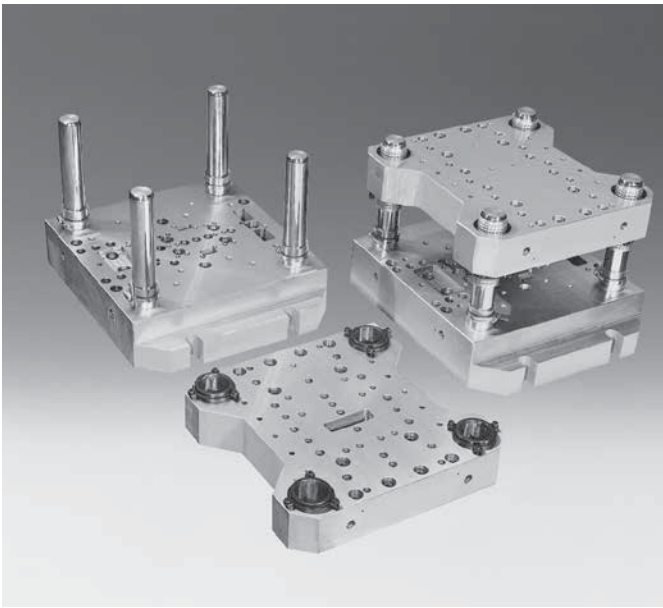



Progression Lamination Die Set Units



Progression Lamination Die Set Unit

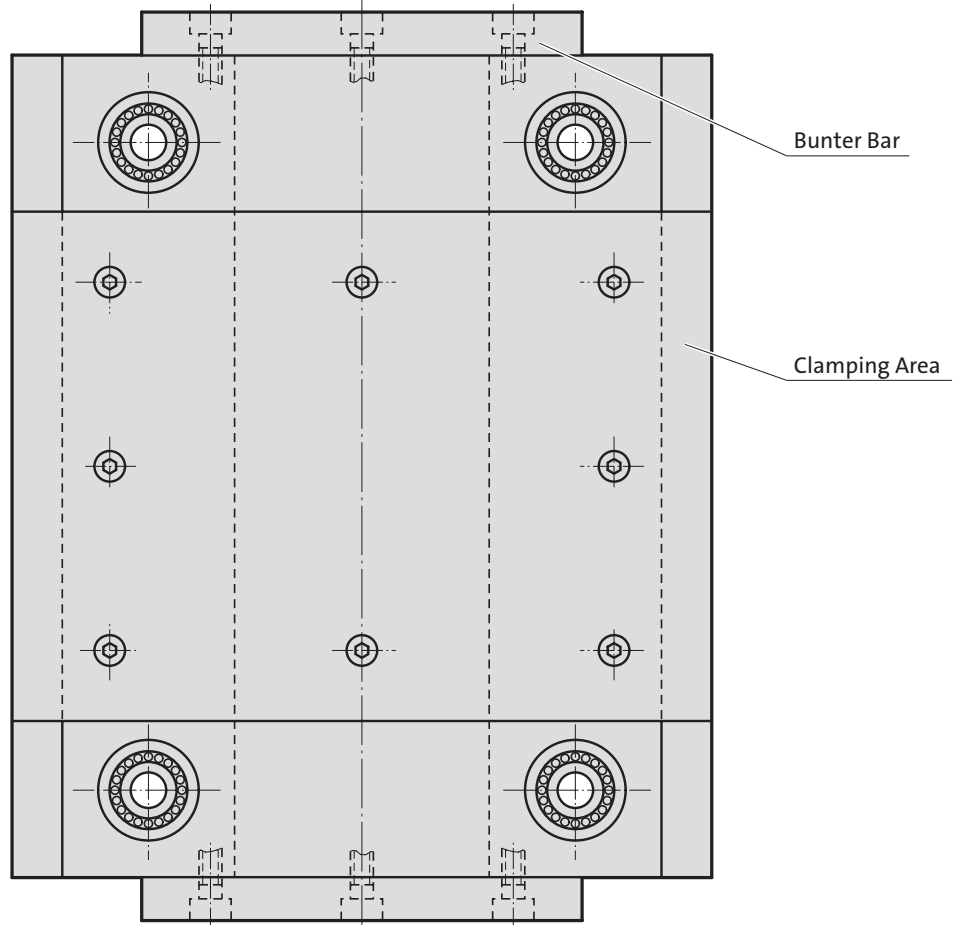
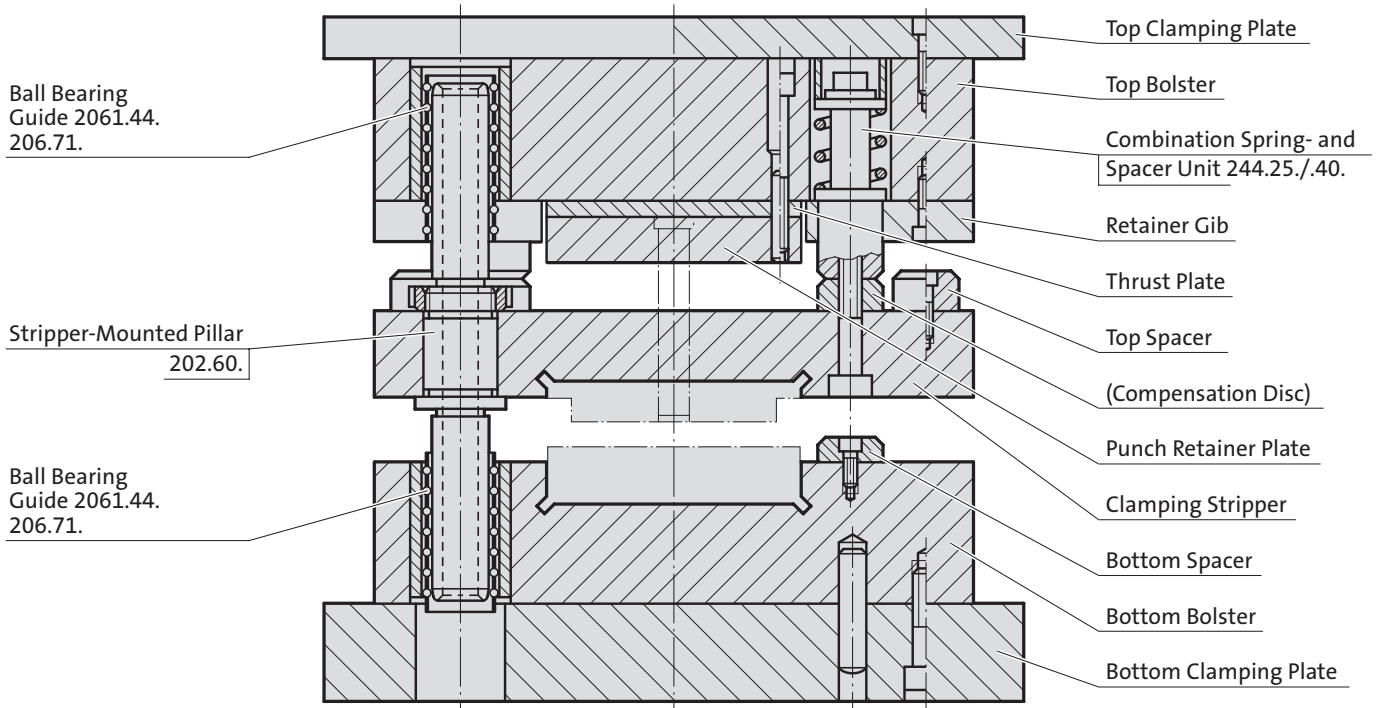

Progression lamination die set unit

Die set units for progression/lamination dies

The accuracy of a stamping die starts with the die set! When we designed these new units, special attention was paid to the stability and load capacity of the guide pillars.

The eventual introduction of the stripper-mounted pillar in its present form brought an eightfold increase in transverse load-carrying capacity relative to conventional pillars; under the same radial force, deflection is reduced to one-eighth.

While modern high-speed presses have made ball bearing guides all but mandatory, the limited load capacity of these bearings remains a disadvantage, calling for generous nominal pillar diameters and the use of more than two guide bearings.

Considerable forces of inertia are encountered during the reversal of stroking motion at speeds in excess of 500 SPM. In order to keep these harmful forces to a minimum, FIBRO Stripper-Mounted Pillars are provided with hollow cores.

Considerations such as these formed the basis for the development of our new die set units with stripper-mounted pillars – a concept that has resulted in greatly improved accuracy, overall stability and speed capacity.

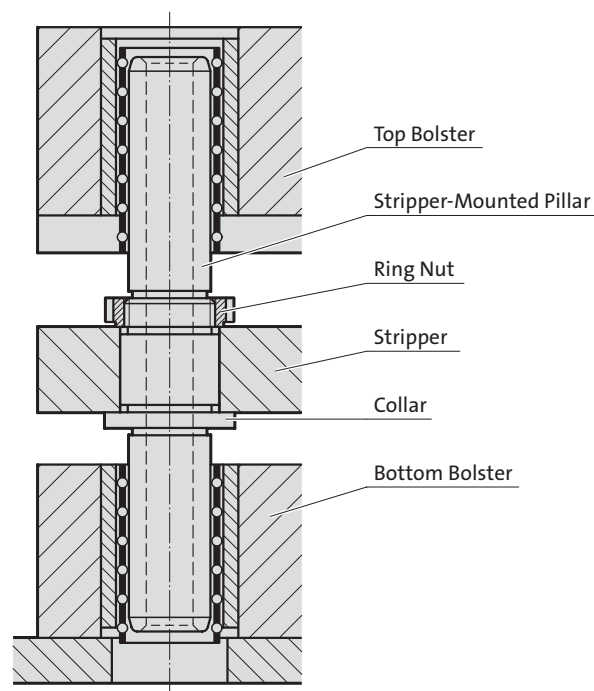

Combination spring/spacer units

Strippers on FIBRO progression/lamination die set units are laid out for the functions of punch guiding and clamping of the stock, derived from preloaded spring/spacer units of highly compact design.

The advantages of these compact units, in accordance with executions 1 to 4, are as follows:

- compactness – the combination of both spring- and spacer functions saves die space
- ease of die maintenance – punch regrinding and replacement, as well as dimensional adaptation, can be done without dismantling of the stripper.
Note: regrinding of punches = regrinding of spacer!
- ease of springs maintenance – after removal of only the top clamping plate, the complete spring/spacer unit can be taken out for replacement etc. This feature applies to executions 1 and 2 only.

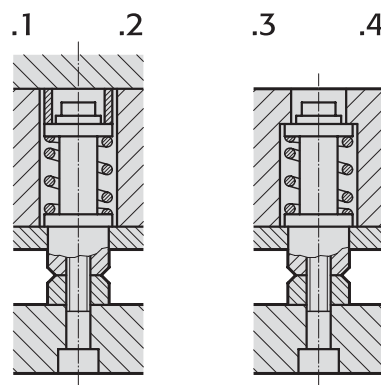

Retaining slots for matrixes and guiding-stripper plate

It is of paramount importance to the accuracy of the final die assembly that both these slots are in perfect vertical alignment, to within a few mm.

From long experience we know that all heavy machining of die set apertures must precede the finish-machining of the two retainer slots for the matrix inserts and the guiding/clamping stripper plate.

Whenever the machining of such apertures is not entrusted to us we will supply our die set units with pre-ground slots only.

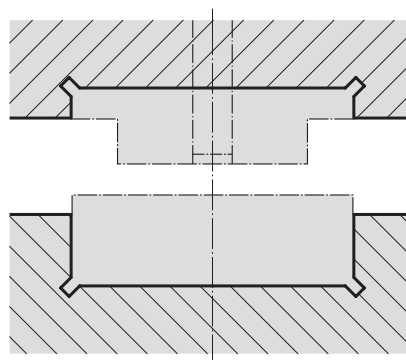

Progression Lamination Die Set Unit

201.50.

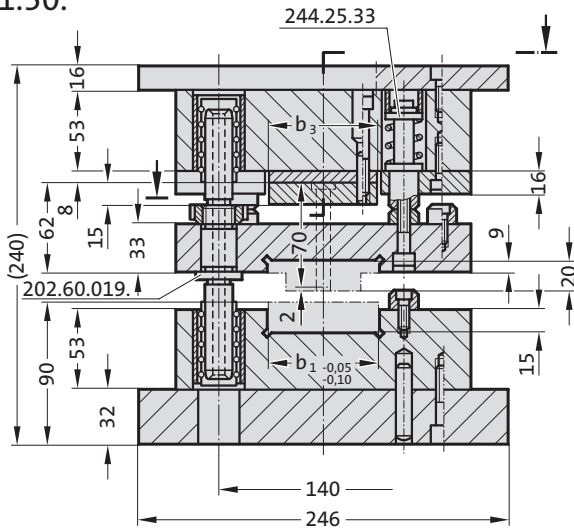

* For the sizes 201.50.2520 and 3020 guide pillars 202.60.025

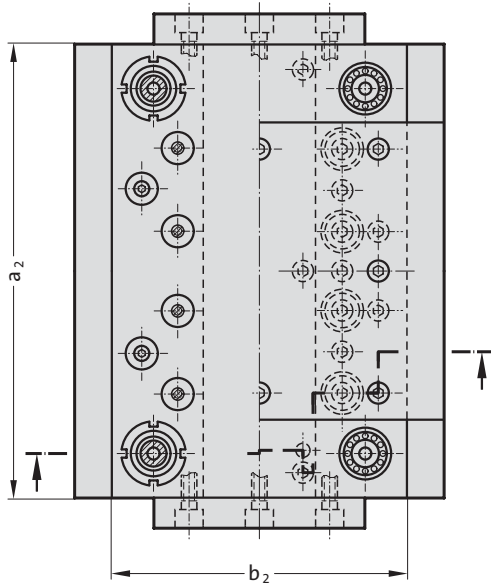

Executions

(mounting of top bolster to ram of press)

201.50.
□□□□.□□□□.□□□□.1
with projecting top
clamping plate

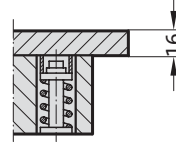

201.50.
□□□□.□□□□.□□□□.2
with threaded hole in top
clamping plate, for threaded
shank

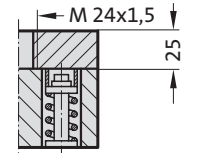

201.50.
□□□□.□□□□.□□□□.3
with threaded hole in top bolster,
for threaded shank

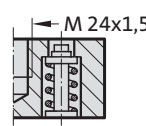

201.50.
□□□□.□□□□.□□□□.4
with clamping pockets
milled in top bolster

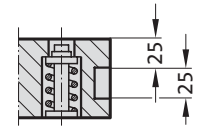

Guide Elements

Ball Bearing Guides

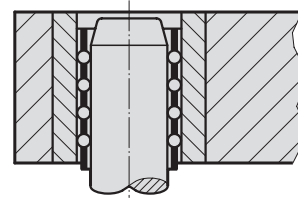

Width of slot b_1 to be determined by customer!

2D-CAD data are available on request for each Die Set Unit. The designer need only draw the active die elements. Prints can be taken from this master.

Die daylight and strip height can be reduced by up to 3 mm through a reduction in the thickness of the Bottom Clamping Plate.

201.50. Progression Lamination Die Set Unit

| Order No Type | Size | Spring Type | ext. dims $a_2 \times b_2$ | b_1 max. | Comb. spring+ spacer unit | b_3 | max. spring compr. (without pre load) (mm) | | | spring preload (mm) | preloading in N (per spring unit) | | | | spring coefficient "c" (N) | | | |
|------------------|----------|----------------|-------------------------------|---------------|------------------------------------|-------|--|-----|-----|---------------------------|--------------------------------------|---------------|-----|----|----------------------------|-------|---------------|----|
| | | | | | | | 241... | 14 | 15 | | 16 | 241.□□.25.032 | 14 | 15 | 16 | 17 | 241.□□.25.032 | 14 |
| 201.50.1320 | □□□.□□.□ | □ | 126 × 196 | 40 | 4 | 40 | 6,0 | 6,0 | 5,0 | 3 | 241 | 354 | 891 | — | 80,3 | 118,1 | 297 | — |
| 201.50.1620 | □□□.□□.□ | □ | 156 × 196 | 50 | 4 | 50 | 6,0 | 6,0 | 5,0 | 3 | 241 | 354 | 891 | — | 80,3 | 118,1 | 297 | — |
| 201.50.2020 | □□□.□□.□ | □ | 196 × 196 | 60 | 6 | 60 | 6,0 | 6,0 | 5,0 | 3 | 241 | 354 | 891 | — | 80,3 | 118,1 | 297 | — |
| 201.50.2520 | □□□.□□.□ | □ | 246 × 196 | 75 | 8 | 75 | 6,0 | 6,0 | 5,0 | 3 | 241 | 354 | 891 | — | 80,3 | 118,1 | 297 | — |
| 201.50.3020 | □□□.□□.□ | □ | 296 × 196 | 75 | 8 | 75 | 6,0 | 6,0 | 5,0 | 3 | 241 | 354 | 891 | — | 80,3 | 118,1 | 297 | — |

Ordering Code (example):

Die Set Unit = 201.50.
 $a_2 \times b_2 = 296 \times 196$ = 3020.
 $b_1 = 75$ mm = 075.
 Springs (type) 241.15. = 15.
 With projecting top clamping plate = 1
 Order No = 201.50.3020.075.15.1

Die Set Units 201.50. can also be supplied in special sizes as well as special executions, acc. to customers' specifications.

Progression Lamination Die Set Unit

Executions

(mounting of top bolster to ram of press)

201.50.

□□□□.□□□□.□□.1
with projecting top clamping plate

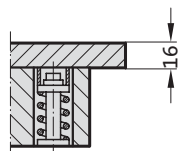

201.50.

□□□□.□□□□.□□.2
with threaded hole in top clamping plate, for threaded shank

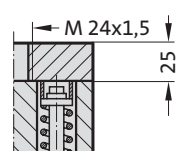

201.50.

□□□□.□□□□.□□.3
with threaded hole in top bolster, for threaded shank

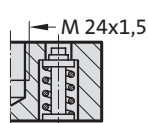

201.50.

□□□□.□□□□.□□.4
with clamping pockets milled in top bolster

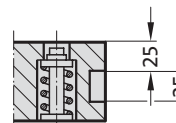

201.50.

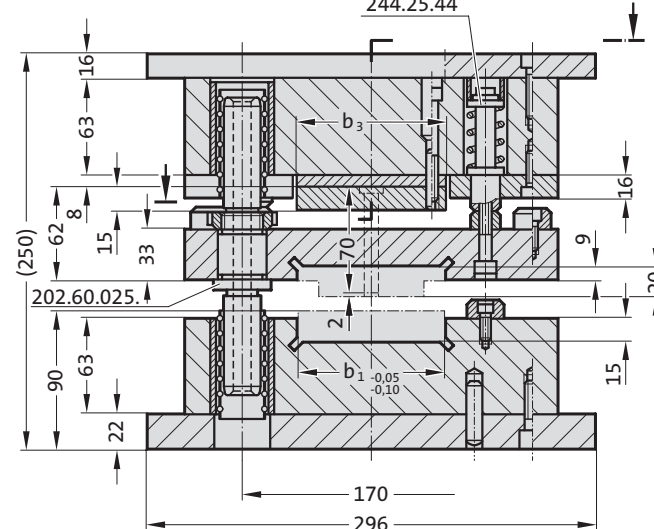

Guide Elements

Ball Bearing Guides

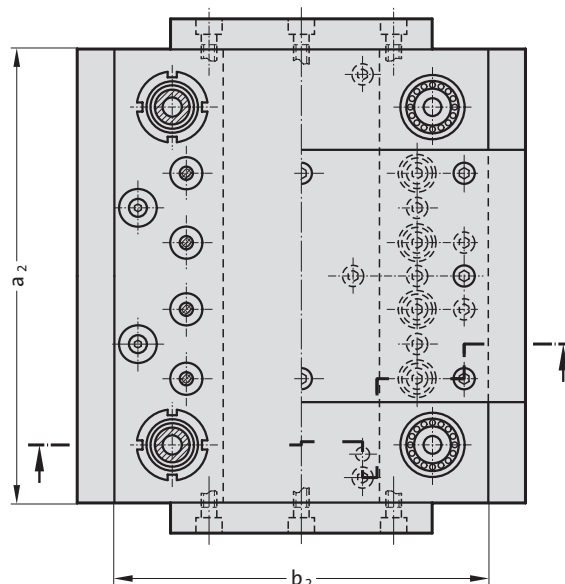
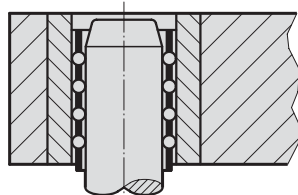

Width of slot b_1 to be determined by customer!

2D-CAD data are available on request for each Die Set Unit. The designer need only draw the active die elements. Prints can be taken from this master.

Die daylight and strip height can be reduced by up to 16 mm through a reduction in the thickness of the Bottom Clamping Plate.

201.50. Progression Lamination Die Set Unit

| Order No | Spring Type | Spring Size | ext. dims $a_2 \times b_2$ | b_1 max. | Comb. spring+ spacer unit | b_3 | max. spring compr. (without pre load) (mm) 241... | | | | spring preload (mm) | preloading in N (per spring unit) 241.□□.25.045 | | | | spring coefficient "c" (N) 241.□□.25.045 | | | |
|--------------|-------------|-------------|----------------------------|------------|---------------------------|-------|---|-----|-----|-----|---------------------|---|-----|-----|-----|--|------|-----|-------|
| | | | | | | | 14 | 15 | 16 | 17 | | 14 | 15 | 16 | 17 | 14 | 15 | 16 | 17 |
| 201.50.1625. | □□□. | □□. | 156 × 246 | 60 | 4 | 60 | 8,0 | 8,0 | 7,8 | 5,4 | 4 | 212 | 323 | 748 | 977 | 53 | 80,8 | 187 | 244,2 |
| 201.50.2025. | □□□. | □□. | 196 × 246 | 75 | 6 | 75 | 8,0 | 8,0 | 7,8 | 5,4 | 4 | 212 | 323 | 748 | 977 | 53 | 80,8 | 187 | 244,2 |
| 201.50.2525. | □□□. | □□. | 246 × 246 | 90 | 8 | 90 | 8,0 | 8,0 | 7,8 | 5,4 | 4 | 212 | 323 | 748 | 977 | 53 | 80,8 | 187 | 244,2 |
| 201.50.3025. | □□□. | □□. | 296 × 246 | 100 | 8 | 100 | 8,0 | 8,0 | 7,8 | 5,4 | 4 | 212 | 323 | 748 | 977 | 53 | 80,8 | 187 | 244,2 |
| 201.50.3525. | □□□. | □□. | 346 × 246 | 100 | 10 | 100 | 8,0 | 8,0 | 7,8 | 5,4 | 4 | 212 | 323 | 748 | 977 | 53 | 80,8 | 187 | 244,2 |

Ordering Code (example):

| | | |
|------------------------------------|---|----------------------|
| Die Set Unit | = | 201.50. |
| $a_2 \times b_2 = 296 \times 246$ | = | 3025. |
| $b_1 = 100$ mm | = | 100. |
| Springs (type) 241.15. | = | 15. |
| With projecting top clamping plate | = | 1 |
| Order No | = | 201.50.3025.100.15.1 |

Die Set Units 201.50. can also be supplied in special sizes as well as special executions, acc. to customers' specifications.

Progression Lamination Die Set Unit

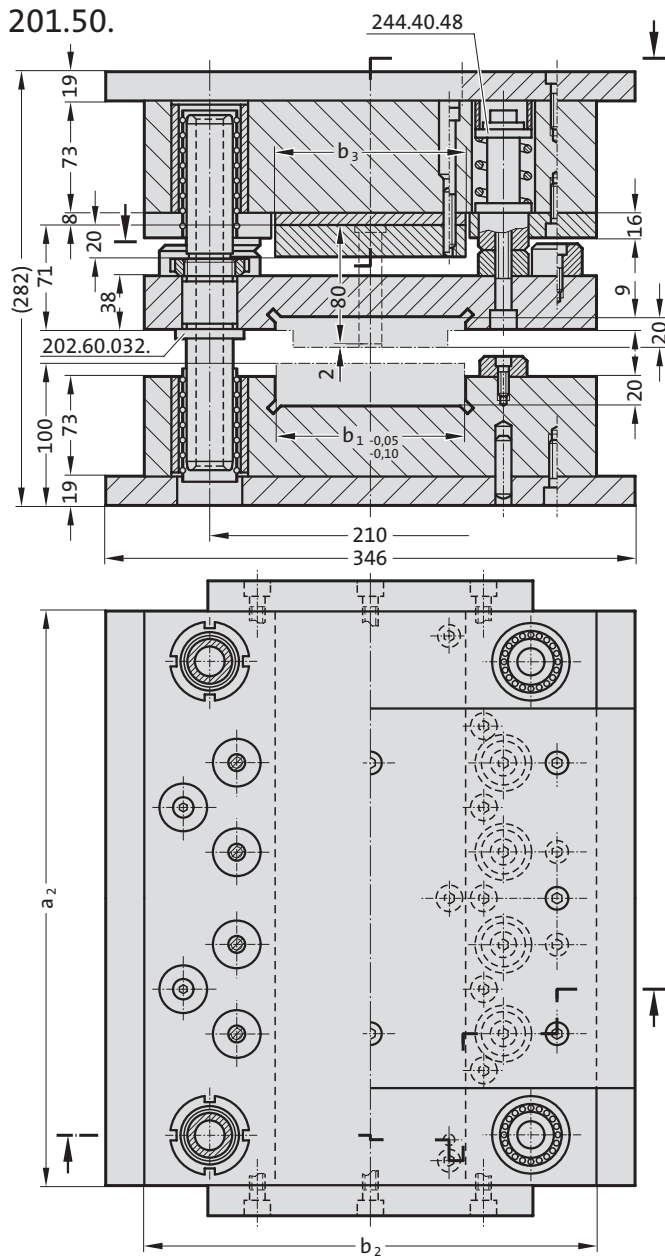

Executions

(mounting of top bolster to ram of press)

201.50.
□□□□.□□□.□□.1
with projecting top
clamping plate

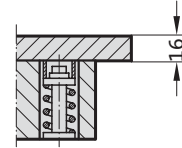

201.50.
□□□□.□□□.□□.3
with threaded hole in
top bolster, for threaded shank

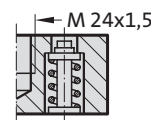

201.50.
□□□□.□□□.□□.2
with threaded hole in top clamping
plate, for threaded shank

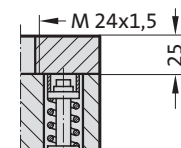

201.50.
□□□□.□□□.□□.4
with clamping pockets milled
in top bolster

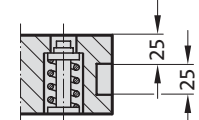

Guide Elements

Ball Bearing Guides

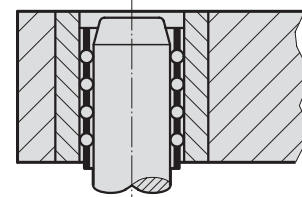

Width of slot b_1 to be determined by customer!

2D-CAD data are available on request for each Die Set Unit. The designer need only draw the active die elements. Prints can be taken from this master.

Die daylight and strip height can be reduced by up to 16 mm through a reduction in the thickness of the Bottom Clamping Plate.

201.50. Progression Lamination Die Set Unit

| Order No Type | Size | Spring Type Exec. | ext. dims $a_2 \times b_2$ | b_1 max. | Comb. spring+ spacer unit | b_3 | max. spring compr. (without pre load) (mm) 241... | | | | spring preload (mm) | preloading in N (per spring unit) 241.□□.25.045 | | | | spring coefficient "c" (N) 241.□□.25.045 | | | |
|------------------|-------------|----------------------|-------------------------------|---------------|------------------------------------|-------|---|-----|-----|-----|---------------------------|---|------|------|------|--|-----|-----|-------|
| | | | | | | | 14 | 15 | 16 | 17 | | 14 | 15 | 16 | 17 | 14 | 15 | 16 | 17 |
| 201.50. 2030. | □□□. □□□. □ | □ | 196 × 296 | 75 | 4 | 75 | 7,0 | 7,0 | 5,0 | 4,2 | 8 | 736 | 1432 | 2800 | 5027 | 92 | 179 | 350 | 628,4 |
| 201.50. 2530. | □□□. □□□. □ | □ | 246 × 296 | 100 | 6 | 100 | 7,0 | 7,0 | 5,0 | 4,2 | 8 | 736 | 1432 | 2800 | 5027 | 92 | 179 | 350 | 628,4 |
| 201.50. 3030. | □□□. □□□. □ | □ | 296 × 296 | 100 | 8 | 100 | 7,0 | 7,0 | 5,0 | 4,2 | 8 | 736 | 1432 | 2800 | 5027 | 92 | 179 | 350 | 628,4 |
| 201.50. 3530. | □□□. □□□. □ | □ | 346 × 296 | 125 | 8 | 125 | 7,0 | 7,0 | 5,0 | 4,2 | 8 | 736 | 1432 | 2800 | 5027 | 92 | 179 | 350 | 628,4 |
| 201.50. 4030. | □□□. □□□. □ | □ | 396 × 296 | 125 | 8 | 125 | 7,0 | 7,0 | 5,0 | 4,2 | 8 | 736 | 1432 | 2800 | 5027 | 92 | 179 | 350 | 628,4 |

Ordering Code (example):

| | |
|------------------------------------|------------------------|
| Die Set Unit | = 201.50. |
| $a_2 \times b_2 = 296 \times 296$ | = 3030. |
| $b_1 = 100$ mm | = 100. |
| Springs (type) 241.15. | = 15. |
| With projecting top clamping plate | = 1 |
| Order No | = 201.50.3030.100.15.1 |

Die Set Units 201.50. can also be supplied in special sizes as well as special executions, acc. to customers' specifications.



Tooling Pallet Die Sets



Fast Exchange System for Pallet Tooling

Description

The fast exchange of pallet-born tooling sets, with the concept of rapid mechanical positioning, meets the demands for:

- lowering of tooling cost
- reduction in setting costs
- faster response to market trends.

Instead of a multitude of complete die set-born press tools, the new system is based on a carrier die set with rapid-exchange features. This die set can remain in the press, while any number of tooling pallet sets can be accommodated expediently and precisely, one at a time.

There are no individual guide elements associated with a tooling pallet set – the necessary guiding remains a function of the carrier die set exclusively.

Tooling pallet sets are mounted to standard carrier plates – the top and bottom tooling simply slides into position, where a stop provides the positioning control, to allow entry of the locating pins upon the required half-turn of each of the four pin actuation levers on the die set. With the tooling pallets now positioned accurately, the hexagonal clamping screws at the front of the die set can be turned with a box spanner, each activating one clamp via an internal cam, moved by threading action of the screw. The cam angle is such that self-locking is obtained.

Press Tool Types

Sets of pallet tooling can be designed as:

- combination progression tools
- compound tools
- draw dies
- bending- and forming dies
- combination tools etc.

Setting and Tryout Aids

The absence of individual guide elements is a fundamental feature of tooling pallet sets which greatly assists the overall economy of the system. In order to facilitate the aligning of top- and bottom tooling, conical centring units can be fitted, thus providing alignment between both members by direct means – even outside the carrier die set, on the toolmaker's bench.

As a further aid for setting and tryout of pallet sets we offer the FIBRO Aligning- and Tryout Press Unit 201.98. with simplified but basically similar positioning- and locking features as the carrier die set.

Fast Exchange System for Pallet Tooling

Setting

- slide each pallet into its position
- positioning
- clamping

These steps can be completed in a minute.

Slide-In Insertion

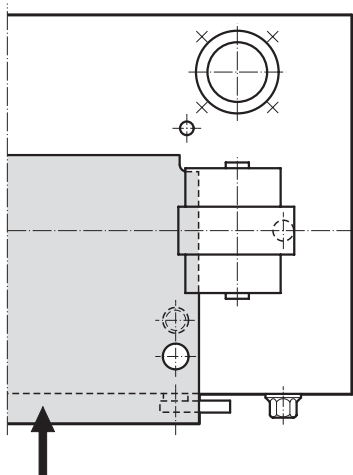

Positioning

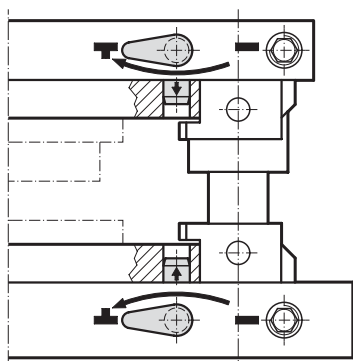

Clamping

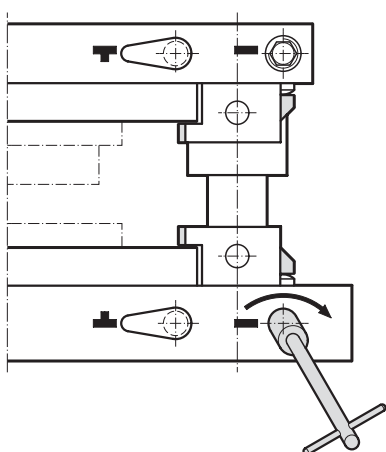

Positioning Aids

Pallet tooling sets can be equipped with conical centring units.

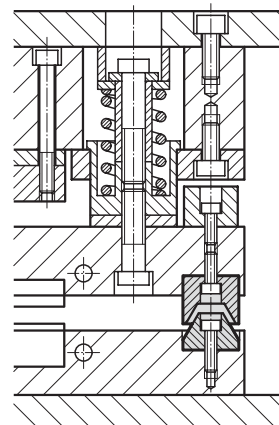

Sheet Thicknesses

Sheet less than 0,4 mm in thickness is normally not recommended for the system – on account of the smaller punch-to-die clearances associated with thin stock materials, where the normal positioning accuracy within the carrier die set (approximately 0,02 mm) becomes insufficient.

However, through fitting of conical centring units the overall alignment accuracy can be improved to an extent where even sheet below 0,4 mm thickness can be processed successfully.

Fast Exchange System for Pallet Tooling

Top Bolster of Pallet Die Set

- 1 top bolster
- 2 pallet carrier plate – for slide-in insertion
- 3 guide bushes – optionally sliding – or ball bearing guides
- 4 clamp
- 5 positioning pin – descends below surface
- 6 positioning pin lever
- 7 stop pin
- 8 clamping screw

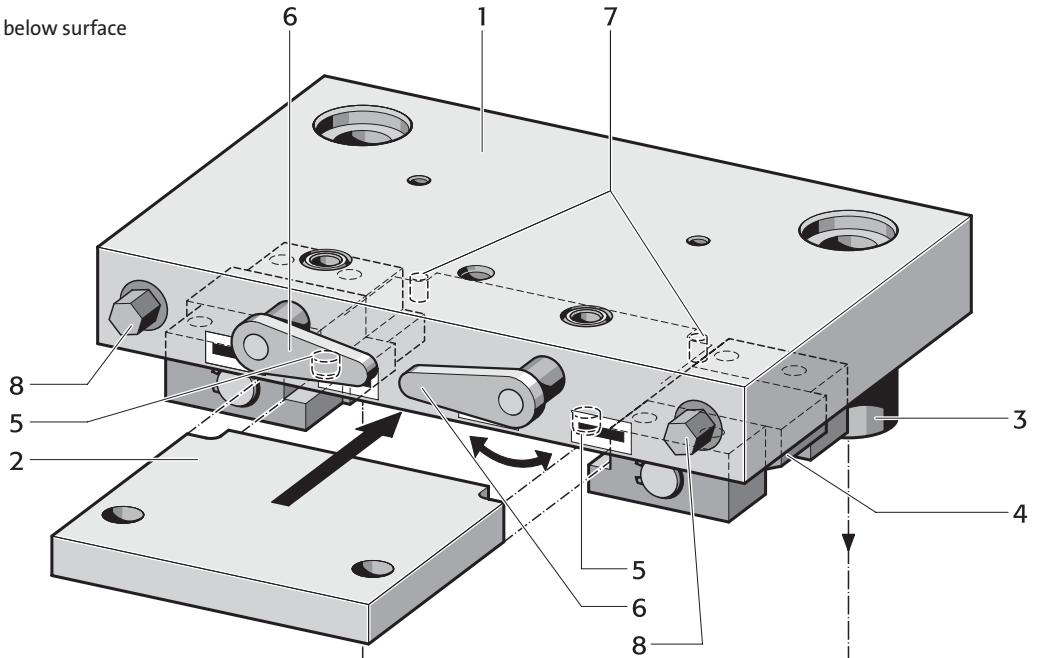

Bottom Bolster of Pallet Die Set

- 1 bottom bolster
- 2 pallet carrier plate – for slide-in insertion
- 3 guide pillar
- 4 clamp
- 5 positioning pin – descends below surface
- 6 positioning pin lever
- 7 stop pin
- 8 clamping screw
- 9 bolster insert plate
- 10 box spanner

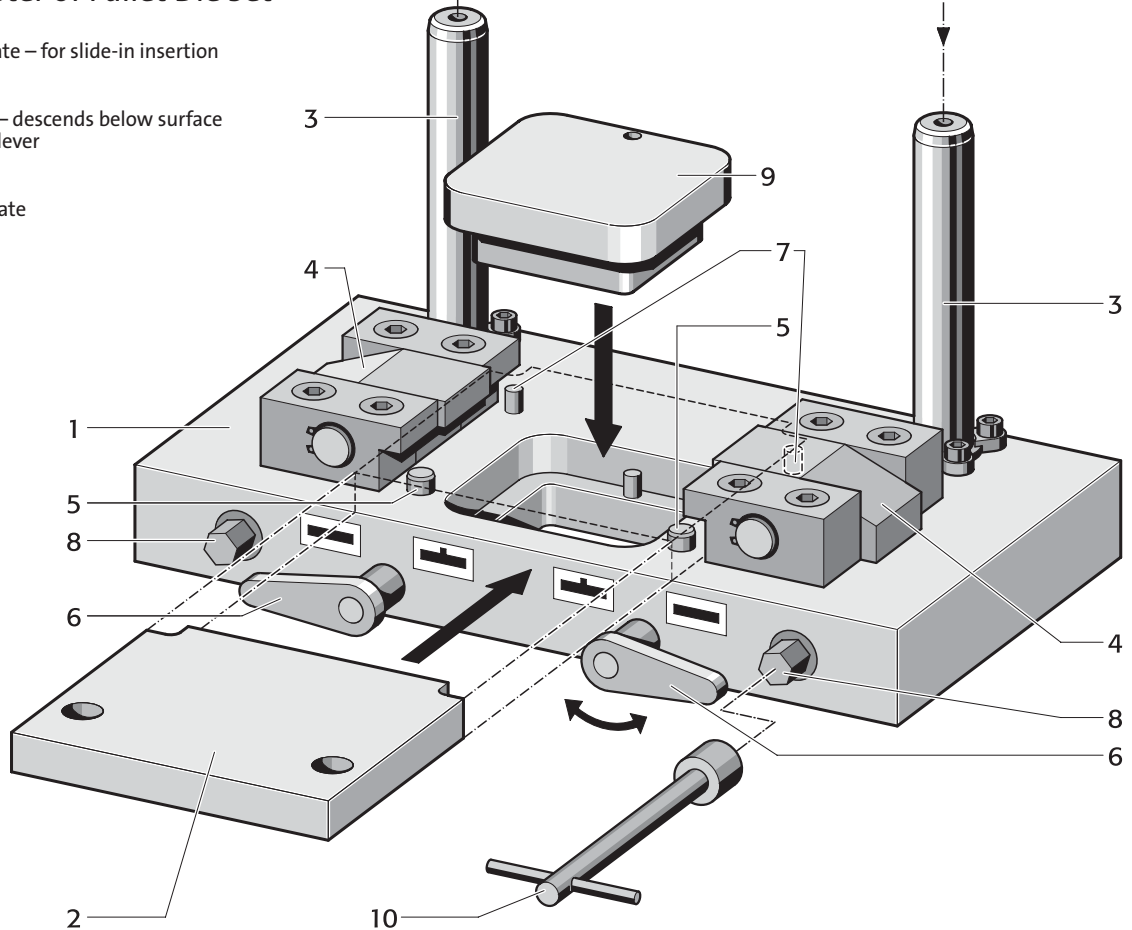

Fast Exchange System for Pallet Tooling

201.95.

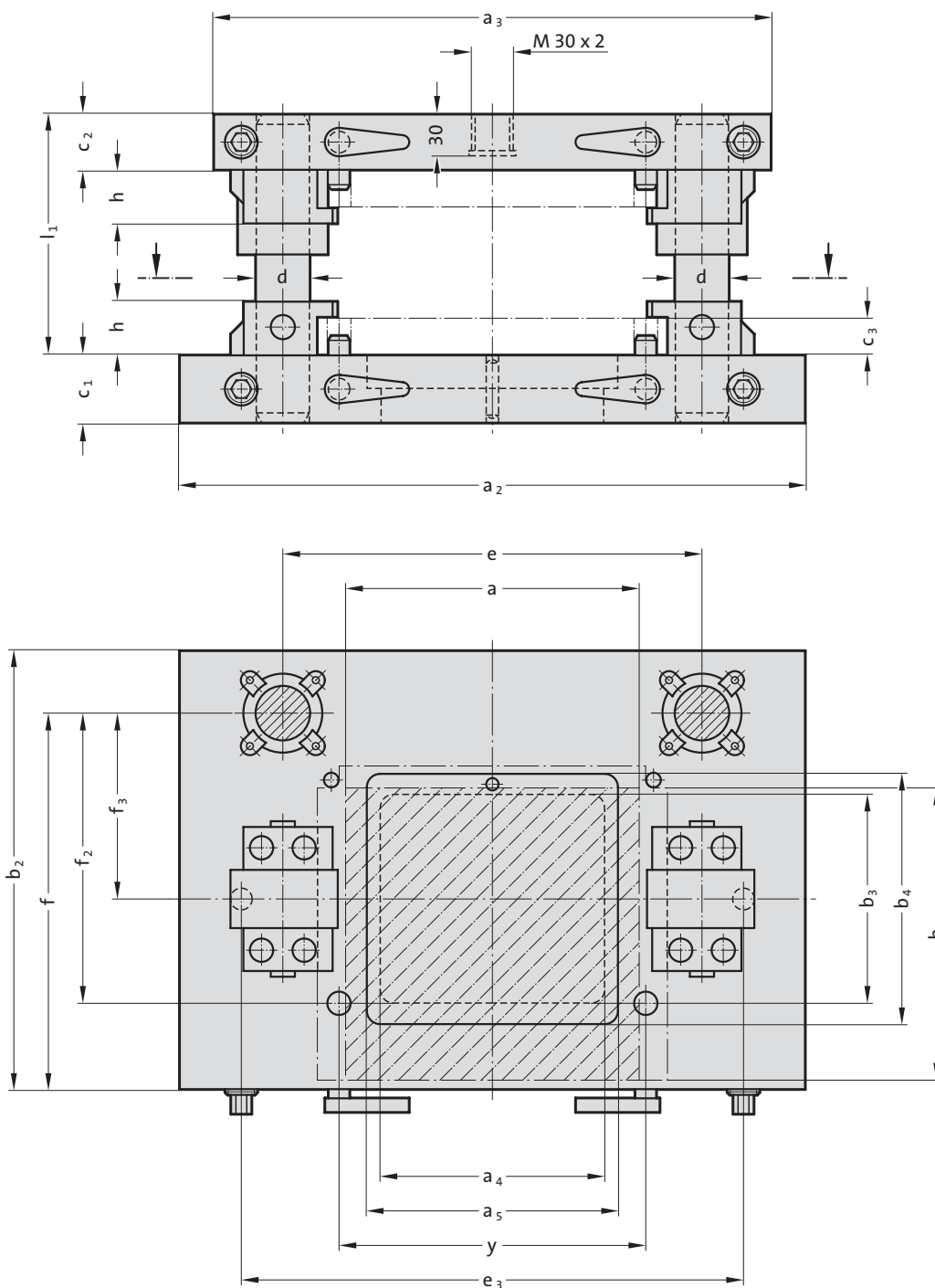

201.95. Fast Exchange System for Pallet Tooling

| Order No | Type of guides* | work area a × b | a ₂ | a ₃ | a ₄ | a ₅ | b ₂ | b ₃ | b ₄ | c ₁ | c ₂ | c ₃ | d | e | y | e ₃ | f | f ₂ | f ₃ | h | l ₁ |
|--------------|-----------------|--------------------|----------------|----------------|----------------|----------------|----------------|----------------|----------------|----------------|----------------|----------------|----|-----|-----|----------------|-----|----------------|----------------|----|----------------|
| 201.95.1010. | | 100 × 100 | 350 | 300 | 80,5 | - | 200 | 60 | 80,5 | 40 | 40 | 16 | 25 | 220 | 120 | 260 | 168 | 113 | 93 | 29 | 160 |
| 201.95.2121. | | 210 × 210 | 450 | 400 | 161 | 180,2 | 315 | 150 | 180,2 | 50 | 40 | 25 | 40 | 300 | 220 | 360 | 270 | 208 | 133 | 38 | 180 |
| 201.95.3030. | | 300 × 300 | 550 | 500 | 241 | 270,5 | 420 | 220 | 250,5 | 63 | 40 | 25 | 40 | 380 | 320 | 460 | 365 | 305 | 185 | 38 | 180 |
| 201.95.3521. | | 350 × 210 | 600 | 550 | 320 | - | 315 | 120 | 150 | 50 | 40 | 25 | 40 | 450 | 370 | 510 | 270 | 208 | 133 | 38 | 180 |

* Type of guides: 831 for sliding guides or 862 for ball guides

Pallet Carrier Plate Bolster Insert Plate

Pallet Carrier Plates

For each pallet tooling set, two carrier plates 201.96. are required – one for mounting the top tooling details, the other for the bottom tooling.
The tooling components are dowed into position.

201.96.

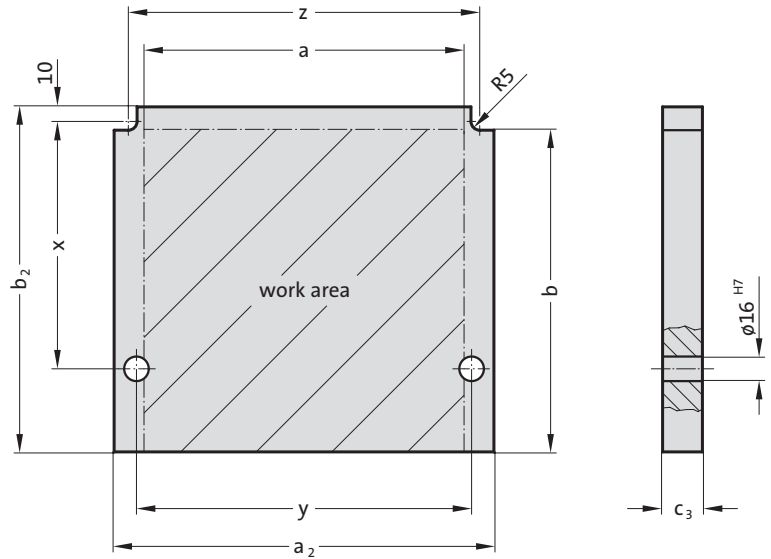

201.96. Pallet Carrier Plate

| Order No | work area a × b | a ₂ | b ₂ | c ₃ | x | y | z |
|-------------|--------------------|----------------|----------------|----------------|-------|-----|-----|
| 201.96.1010 | 100 × 100 | 150 | 115 | 16 | 50,1 | 120 | 130 |
| 201.96.2121 | 210 × 210 | 250 | 225 | 25 | 160,1 | 220 | 230 |
| 201.96.3030 | 300 × 300 | 350 | 315 | 25 | 250,1 | 320 | 330 |
| 201.96.3521 | 350 × 210 | 400 | 225 | 25 | 160,1 | 370 | 380 |

Bolster Insert Plates

201.97.

This insert plate has to be added to a tooling pallet set if:

- scrap holes near the centre require additional support
- spring cushions or bottom ejectors have to be employed
- other features of specific die designs require an individual insert plate

Bolster insert plates have a dowel that makes them non-reversible.

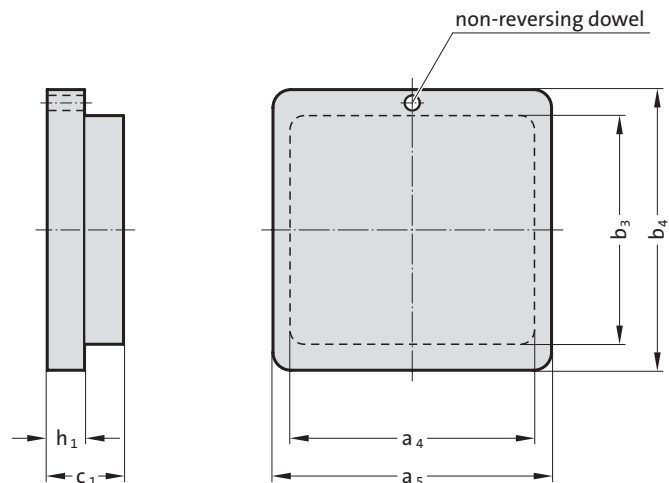

201.97. Bolster Insert Plate

| Order No | work area a × b | a ₄ | a ₅ | b ₃ | b ₄ | c ₁ | h ₁ |
|-------------|--------------------|----------------|----------------|----------------|----------------|----------------|----------------|
| 201.97.1010 | 100 × 100 | 80 | – | 60 | 80 | 40 | 20 |
| 201.97.2121 | 210 × 210 | 160 | 180 | 150 | 180 | 50 | 25 |
| 201.97.3030 | 300 × 300 | 240 | 270 | 220 | 250 | 63 | 30 |
| 201.97.3521 | 350 × 210 | 320 | – | 120 | 150 | 50 | 25 |

Aligning- and Tryout Press Unit

201.98.

Description

These press units have manual actuation by way of a hydraulic jack which forces the guided bolster upwards. In the toolroom they serve as tryout- and setting press, especially for tooling pallet sets. For the latter purpose they are equipped with simplified but functionally similar features for positioning and clamping as those in FIBRO Tooling Pallet Die Sets.

Moreover the press units provide ideal facilities for the press-fitting of pillars and bushes etc. – or their removal. For blueing-in and tryout of all sorts of press tools they soon prove themselves as an indispensable workshop facility, with a maximum thrust of 10 tons.

Material:

Plate: St 52-2

Execution:

Headed ball bearing guide bushes, hydraulic jack, 10 tons capacity

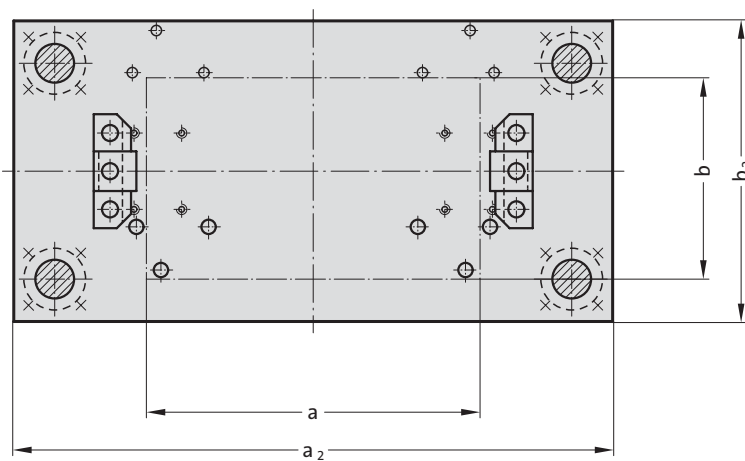
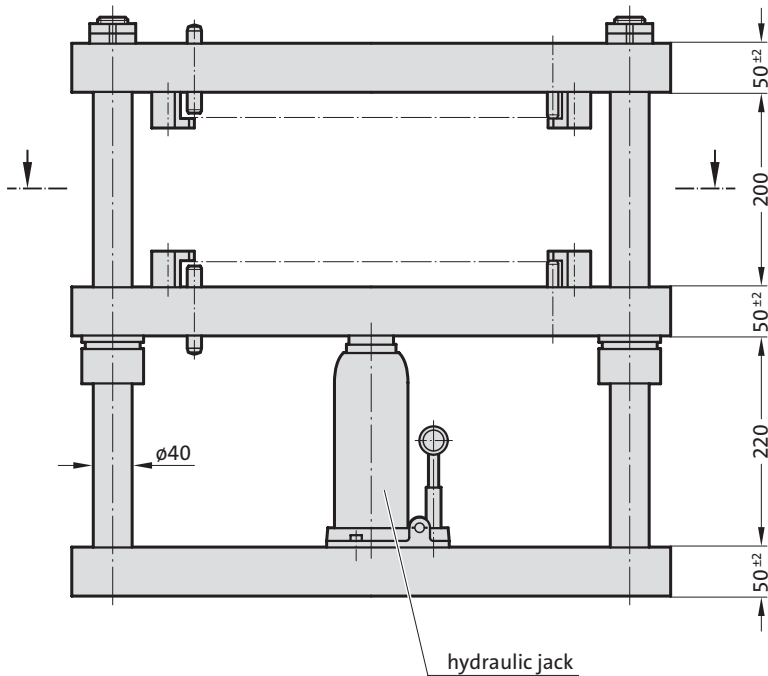

201.98. Aligning- and Tryout Press Unit

| Order No | work area | | |
|-----------------|-----------|----------------|----------------|
| | a × b | a ₂ | b ₂ |
| 201.98.1010.863 | 100 × 100 | 315 | 250 |
| 201.98.3030.863 | 210 × 210 | 630 | 315 |
| 201.98.3030.863 | 300 × 300 | 630 | 315 |
| 201.98.3030.863 | 350 × 210 | 630 | 315 |